

---

# **Smart DLogger User Manual**

GIT Co., Ltd.



---

## Table of Contents

---

1. Overview . . . . .	5
1.1 Preparation . . . . .	5
1.2 Writing rules . . . . .	5
1.3 Concept . . . . .	5
1.4 Overview and Goal . . . . .	8
1.5 Procedure . . . . .	9
1.6 Configuration of DLogger hardware . . . . .	9
1.7 Situation of application of DLogger . . . . .	17
2. Installing programs . . . . .	19
2.1 Setting PC environment before installing programs . . . . .	19
2.2 Installing Smart DLogger Program . . . . .	19
2.3 Deleting Smart DLogger Program . . . . .	21
2.4 Updating Smart DLogger Program . . . . .	23
3. Pairing Bluetooth . . . . .	23
3.1 Information on concept . . . . .	23
3.2 Installing a Bluetooth dongle . . . . .	23
3.3 Pairing Compact VCI Bluetooth . . . . .	28
3.4 Pairing Trigger Module for CVCI Bluetooth . . . . .	29
3.5 Pairing Compact VCI with Trigger Module for CVCI . . . . .	32
3.6 Paring VCI-II Bluetooth . . . . .	35
3.7 Pairing VCI-II with Trigger Module for VCI-II . . . . .	35
3.8 Paring CVCI-II Bluetooth . . . . .	37
3.9 Pairing CVCI-II with Trigger Module for CVCI-II . . . . .	37
4. Updating firmware . . . . .	38
4.1 Compact VCI firmware . . . . .	38
4.2 Trigger Module for CVCI firmware . . . . .	39
4.3 VCI-II firmware . . . . .	41
4.4 CVCI-II firmware . . . . .	43
5. Smart DLogger Program . . . . .	45
5.1 Explanation of functions . . . . .	45
5.2 Generating events . . . . .	46
5.3 Conversion of recording files . . . . .	66
5.4 Analyzing recorded data . . . . .	66
6. DLogger analyzer . . . . .	66

---

6.1 Explanation of functions . . . . .	66
6.2 Method of analysis . . . . .	79
6.3 Cases of analysis . . . . .	84
7. User site . . . . .	87
7.1 How to request authority . . . . .	87
7.2 Notice . . . . .	88
7.3 Library . . . . .	89
7.4 Request for analysis . . . . .	89
7.5 Community . . . . .	91
8. How to utilize DLogger devices . . . . .	92
8.1 Utilizing 1 set of DLogger devices . . . . .	93
8.2 Utilizing 2 set of Compact VCI . . . . .	97
9. Contacts . . . . .	98

---

## 1. Overview

---

This manual explains all the functions that use Smart DLogger to the beginners to use Smart DLogger. This manual does not require any preliminary knowledge about Smart DLogger but assumed that Windows O/S is available.

### 1.1 Preparation

---

Prepare a system before following the manual.

In order to follow the manual, you should install and run Smart DLogger Program in your PC. Smart DLogger may be run using the icon on the desktop or in the Start Menu.

Check that corresponding file is in the position described below.

C:\Program Files\WGDS-inside2

Check that an internet browser is installed in the PC to use Smart DLogger Program and check the connection with the browser.

### 1.2 Writing rules

---

This manual uses following reading rules when explaining works.

- “Click OK” means “Click OK button.”
- Smart DLogger main screen, which appears when Smart DLogger is started, is called Main Toolbar in the whole of this manual.

The graphic user interface included in the instructions of this manual is basically operated using a mouse.

### 1.3 Concept

---

In this part, main concepts and procedures to be used in this manual are introduced.

Such concepts are needed to use and utilize Smart DLogger.

#### 1.3.1 Information on concept

---

##### 1) Data measurement

Sensors assess the state of an engine. Sensors measure engine parameters and convert the measurements into the values in order to be used by ECU.

Measurement consists of the work to sample and record all the sensor values for a specific period. The records obtained by aforesaid method explain the motions of the engine responding to the set of specific calibration values.

##### 2) Calibration

Calibration is the work to control the engine to show the motions to meet the intension of ECU (Electronic Control Unit). For this, ECU uses a feedback process. It measures the state of the engine using sensors and changes the state of engine using an actuator in order to show the intended motions. It measures and adjusts new state of engine repeatedly until equilibrium state is achieved.

---

Calibration is a process to adjust feedback parameters to that a car shows intended motions when equilibrium state is achieved. As the state of a car is continuously changed during running, many equilibrium states exist. Such equilibrium state is called a process point, in general. As a car is a nonlinear system, the control algorithm is depended on arithmetic calculation and the values of feedback cannot be determined. Instead, the control algorithm inquires of intended actuator setting values in a specific table set using the sensor values as the reference values for inquiry. Calibration consists of the work to determine the values in a specific table set. Same ECUs cannot have the set of different effective calibration values to implement different engine motions. For example, a set is applied to a high-speed vehicle and another set may be applied to a low fuel-consumption vehicle.

### 3) Smart DLogger

Smart DLogger provides the users with graphic user interface and the hardware to access ECU in order to support smooth and qualified data measurement.

### 4) Variables, measurement variables, and calibration variables

The term of variables means measurement variables and all types of calibration variables. In general, measurement variables are transmitted by sensors and may be used as the inquiry values of calibration variables. Also, it is possible to measure induced or calculated property values and measure calibration variables with application of corresponding setting.

Smart DLogger records measurement variables only and analyzes the data.

### 5) Management of DB

The management data (files of management variables), which meets the symptom of each system of each kind of vehicles for Smart DLogger, is managed by the DB of R&D center server. Accessing the data, reorganizing the data, and generating and managing the data are done through the manager interface in order to use and manage the date efficiently.

### 6) Symptom

It is the set of measurement variables which meets each symptom of each system.

The symptom is saved in DB. The user may call it and may set the variables to meet the symptom using Smart DLogger.

### 7) Project

Project is defined as the whole systems related with DLogger measurement and consists of communication speed, DAQ (Data Acquisition) size, and the data sets

that reflect the values of variables. Project is referred to in DB.

8) Configuration of hardware

The configuration of hardware is defined as the hardware that is used for specific work. In case of application hardware, it is defined as the project to be used and corresponding data sets.

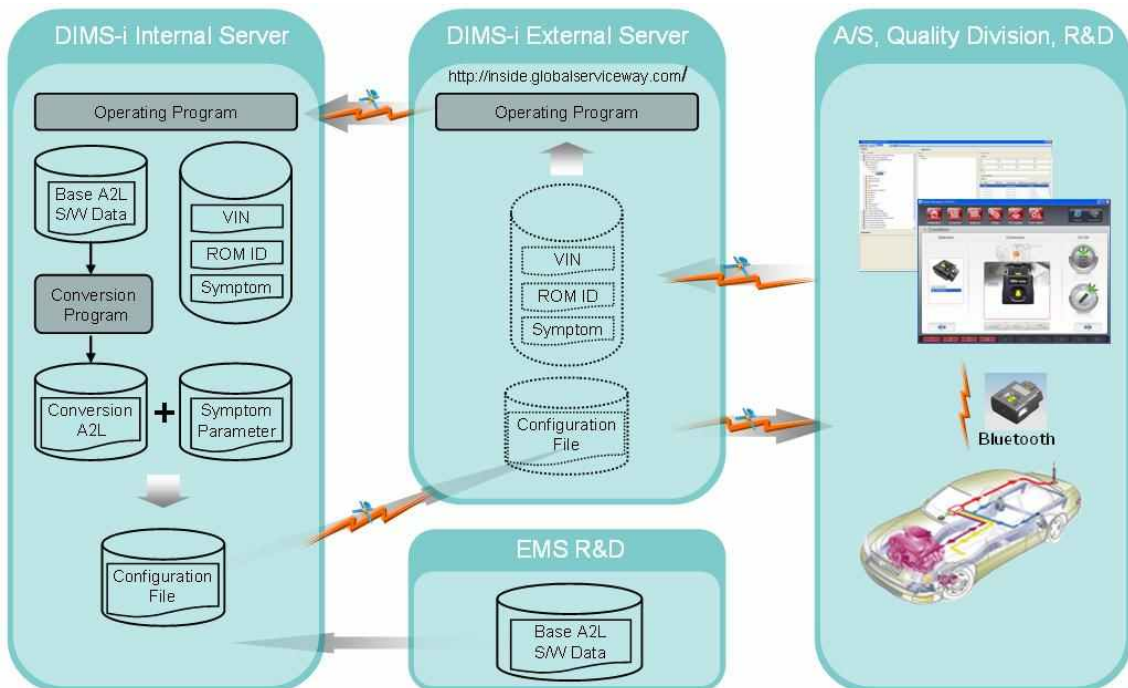
9) DLogger analyzer

DLogger Analyzer Program is an offline tool to display and analyze the recorded measurement data. This program is run as an own program screen and is run in display mode or analysis mode. However, online measurement is impossible in case of DLogger Analyzer.

1.3.2 Concept applied to DLogger

Fig. 1-1 shows a process to generate DLogger event data. For example, in case of an engine, when ECU reads the information on ROM ID and VIN and the user selects Symptom, the information is sent to the server, an event file is generated to meet the information, and an event file is generated in DLogger devices. Therefore, recording is possible when a specific symptom is generated.

Fig. 1-1 DLogger process



---

Fig. 1-2 shows vehicle communication network. Where, DLogger collects needed data from each system through communication such as CCP, XCP, KWP DDLI, and CAN monitoring related with vehicle communication.

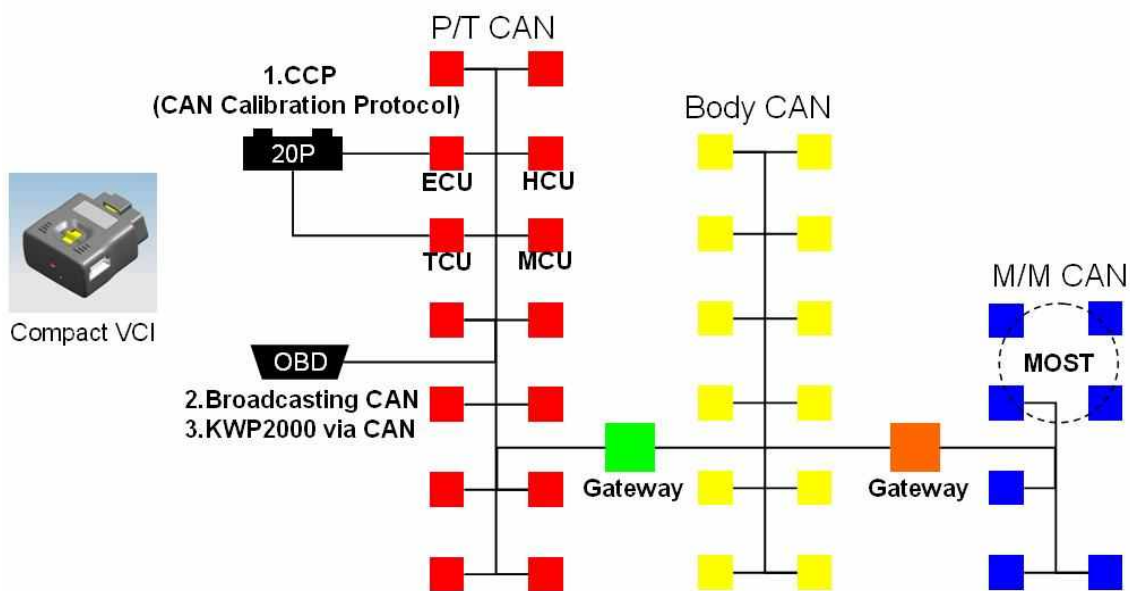
(CCP : Can Calibration Protocol)

(XCP : Extended Calibration Protocol)

(KWP DDLI : KWP Dynamically Define Local Identifier)

(CAN Monitoring)

Fig. 1-2 Vehicle communication network



#### 1.4 Overview and Goal

---

Based on this manual, you may perform the whole process to set the measurement variables to meet the symptom of each system, record data, converts recorded files for analysis programming, and analyze the data, using Smart DLogger Program.

- 1) Installing program: Before installing Smart DLogger Program, you are informed of PC environment setting and program installation/deletion.
- 2) Pairing Bluetooth: You are informed of installation of Bluetooth dongle, the method to pair DLogger devices.
- 3) Updating firmware: You are informed of the method to update DLogger devices.
- 4) Generating Smart DLogger events: You are informed of the method to generate event files to meet the system and symptom using Smart DLogger Program.
- 5) Converting Smart DLogger recording files: You are informed of the method of conversion so that you may see recorded data



---

using an analysis program after the data is recorded.

- 6) Analyzing recorded data: You are informed of the method to analyze recorded data using an analysis program.
- 7) DLogger analyzer: You are informed of various functions and methods of analysis programs when analyzing recorded data using analysis programs.
- 8) User site: You are informed of the methods to request analysis and the various functions and analysis of user site.

## 1.5 Procedure

---

This manual guides you to each step of work and explains the method to perform suggested works in detail.

## 1.6 Configuration of DLogger hardware

---

### 1.6.1 Compact VCI

---

- 1) Compact VCI (CVCI): Main body that performs communication and recording
- 2) Trigger module for CVCI : The signal to notice the starting time of manual trigger ; recording is done by this signal.
- 3) SD card: A flash memory card to store event files and recorded data; it supports 4GB basically and up to 64G.
- 4) USB card reader: A device to recognize SD card as an USB
- 5) Trigger module extension cable: An auxiliary cable for convenient use of trigger module; the positions of cigar jacks are different depending upon the properties of vehicles.
- 6) 8 to 20P cable: In case of Mu, Tau, Lambda, and HEV engines, CCP and CAN monitoring lines are at engine room 20-pin cable; this cable is used when the above engines use CCP and CAN monitoring communication.  
(It is used when engine room 20-pin cable has the pin for power and earth)
- 7) Bluetooth dongle: A Bluetooth device to be used after installation in the external USB when PC has not Bluetooth device
- 8) Industrial SD card (optional): When Compact VCI is installed in the engine room, more reliable data may be stored in this media in bad environment in terms of temperature and vibration, etc.
- 9) 16 to 20P cable (optional): In case of Mu, Tau, Lambda, and HEV engines, CCP and CAN monitoring lines are at engine room 20-pin cable ; this cable is used when those engines use CCP and CAN monitoring communication.

---

(It is used when engine room 20-pin cable has no the pins for power and earth)  
10) Body CAN cable (optional): It is used for body CAN monitoring.

Fig. 1-3 Compact VCI hardware



1) CVCI



2) Trigger Module for CVCI



3) SD card



4) USB Card Reader



5) Extension Cable (for Trigger Module)



6) 8 to 20P Cable (for Lambda, Mu, Tau)



7) Bluetooth Dongle



8) Industrial SD Card (Optional)



9) 16 to 20P Cable (for Lambda, Mu, Tau)  
(Optional)



10) Body CAN Cable (Optional)

Fig. 1-4 Specification of SD card

Size	32mm x 24mm x 2.1mm
Op. Voltage	2.7V~3.6V
Op. Temperature	-25°C(-13°F) ~ 85°C(185°F)
Durability	10,000 insertion/removal cycles
Weight	2g

Specification of common SD card

▪ Interface(connector)	SD flash card connector
▪ Form Factor	SDHC flash card
▪ Flash Type	SLC
▪ Capacity(GB)	4GB
▪ Max. R/W Performance(MB/s)(Vary by density)	Read: 18MB/s, Write: 14MB/s
▪ Op. Voltage(V)	2.7V ~ 3.6V
▪ Power Consumption(W)	0.72W
▪ Op. Temp.(°C)	- 40°C ~ 85°C
▪ Storage Temp.(°C)	- 40°C ~ 85°C
▪ Humidity(%)	0% ~ 95%
▪ Shock(G)	600G
▪ Vibration(Hz/G)	20G (Peak-to-Peak), 20Hz to 2000Hz(Frequency)
▪ Dimensions(mm)	24mm x 32mm x 2.1mm
▪ MTBF(hours)	1,000,000 hours

Specification of industrial SD card

---

## 1.6.2 VCI-II

---

- 1) VCI-II: Main body that performs communication and recording
- 2) Trigger module for VCI-II : The signal to notice the starting time of manual trigger ; recording is done by this signal.
- 3) Trigger module extension cable: An auxiliary cable for convenient use of trigger module; the positions of cigar jacks are different depending upon the properties of vehicles.
- 4) 30pin to USB cable : This cable is used when to connect VCI-II and PC.
- 5) Bluetooth dongle: A Bluetooth device to be used after installation in the external USB when PC has not Bluetooth device
- 6) 30pin to 20pin cable : In case of Mu, Tau, Lambda, and HEV engines, CCP and CAN monitoring lines are at engine room 20-pin cable; this cable is used when the above engines use CCP and CAN monitoring communication. (It is used when engine room 20-pin cable has the pin for power and earth)
- 7) 16 to 20P cable (optional): In case of Mu, Tau, Lambda, and HEV engines, CCP and CAN monitoring lines are at engine room 20-pin cable ; this cable is used when those engines use CCP and CAN monitoring communication. (It is used when engine room 20-pin cable has no pins for power and earth)
- 8) Body CAN cable (optional): It is used for body CAN monitoring.

---

Fig. 1-5 VCI-II



1) VCI-II



2) Trigger module for VCI-II



3) Trigger module extension cable



4) 30pin to USB cable



5) Bluetooth dongle



6) 30pin to 20pin cable



7) 16pin to 20pin cable (optional)



8) Body CAN cable (optional)

---

### 1.6.3 CVCI-II

---

- 1) CVCI-II: Main body that performs communication and recording
- 2) Trigger module for CVCI-II : The signal to notice the starting time of manual trigger; recording is done by this signal.
- 3) Trigger module extension cable: An auxiliary cable for convenient use of trigger module; the positions of cigar jacks are different depending upon the properties of vehicles.
- 4) 30pin to USB cable : This cable is used when to connect CVCI-II and PC.
- 5) 30pin to 20pin cable : In case of Mu, Tau, Lambda, and HEV engines, CCP and CAN monitoring lines are at engine room 20-pin cable; this cable is used when the above engines use CCP and CAN monitoring communication. (It is used when engine room 20-pin cable has the pin for power and earth)
- 6) Body CAN cable : It is used for body CAN monitoring.
- 7) CAN Monitoring cable : This cable is used when CAN Monitoring symptom.
- 8) 16 to 20P cable (optional): In case of Mu, Tau, Lambda, and HEV engines, CCP and CAN monitoring lines are at engine room 20-pin cable ; this cable is used when those engines use CCP and CAN monitoring communication. (It is used when engine room 20-pin cable has no pins for power and earth)

---

Fig. 1-6 CVCI-II



1) CVCI-II



2) Trigger module for CVCI-II



3) Trigger module extension cable



4) 30pin to USB cable



5) 30pin to 20pin cable



6) Body CAN cable



7) CAN Monitoring cable



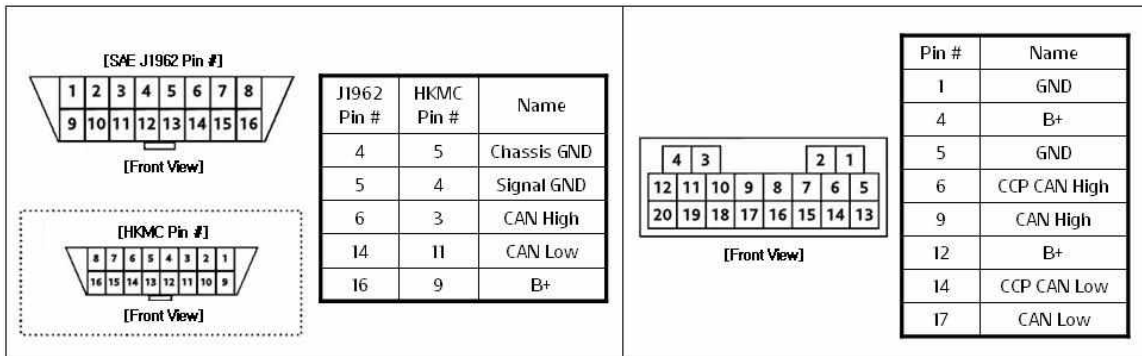
8) 16pin to 20pin cable (optional)



#### 1.6.4 Information on diagnosis connector pins

OBD 16-pin connector is the standard but the specification of engine room 20-pin connector may not have some pins depending upon vehicle.

Fig. 1-7 Information on diagnosis connector pins



Indoor 16-Pin Connector

Engine 20-Pin Connector

#### 1.7 Situation of application of DLogger

The communication line was changed from K line to CAN in 2007 and DLogger supports the vehicles to which CAN was applied since 2007. It supports the whole systems including engine, transmission, and body system.

##### 1.7.1 Protocol

In terms of protocol, it supports CCP (Can Calibration Protocol), XCP (Extended Calibration Protocol), KWP DDLI (Dynamically Define Local Identifier), and CAN Monitoring.

##### 1.7.2 System

The systems to which DLogger is applied are shown in the table.

Fig. 1-8 Situation of DLogger application

System	Protocol	EMS		Engine Type	BOOT	Remarks	Expert DLogger	Smart DLogger	
		Maker	H/W Ver.						
Engine	CCP	Gasoline	KEPICO	M(G)7.9.8	$\psi / \alpha / \epsilon$	MGT.9.8		○	○
				VM17		MEG17.9.12		○	○
				ME7.9.8	ME7.9.8	HEV	○	○	
				KMG	K	KME1.9.0	Bi-Fuel / FFV	○	○
				ME17	$\psi / \tau / \lambda / \nu$	ME17.9.1		○	○
			CONTINENTAL	SIM2K-140	$\theta$	670	2.0	○	○
					671	2.4	○	○	
					690	2.0	○	○	
					691	2.4	○	○	
					692	2.0/2.4	○	○	
					694	MPI Turbo	○	○	
				SIM2K-240	6H3	HEV (YF / TF)	○	○	
		605			GDI / Turbo GDI	○	○		
		692			6속 (2.0/2.4)	○	○		
		SIM2K-241			$\nu$	611	Binary	○	○
					612	Linear	○	○	
					618	CWVL	○	○	
		SIM2K-341	6H4	HEV (YF / TF)	○	○			
			69A	LPI	○	○			
			SIM2K-IB	$\theta$	65L	LPI-HFB (2.0 / 2.7)	○	○	
				$\nu$	6HL	LPI-HFB (HEV-1.6)	○	○	
			DELPHI	MT38	$\mu / \lambda$	8R18p22		○	○
				MT86		8R18p31		○	○
		EDC17C		UII	E610		○	○	
	EDC17C	R / SII		E609		○	○		
	Diesel	BOSCH	EDC16C	U / D / A	E373		○	○	
			EDC16CP	S	E372		○	○	
			DELPHI	DCM3.2AP	J2.9	C5.1 / C5.3		○	○
DCM3.7AP				UII 1.4 / All	C2.1		○	○	
KWP DDLI	Diesel	DELPHI	DCM3.2AP	J2.9	C5.1 / C5.3		○	○	
			DCM3.7AP	UII 1.4 / All	C2.1		○	○	
Auto Transaxle	CCP						○	×	
	XCP						○	×	
Power Train	P-CAN	High Speed CAN					○	×	
Body	B-CAN	Low Speed CAN					○	×	
	H-CAN	High Speed CAN					○	○	
	C-CAN						○	○	
HEV	ECU						○	×	
	HCU						○	○	
	TCU						○	×	
	MCU						○	×	
	BMS							○	○
								○	×

---

## 2. Installing programs

---

This chapter has the title of “Installing programs” and informs all the users, who install and maintain Smart DLogger Program, of the detailed procedures to install and delete the program in/from PC.

### 2.1 Setting PC environment before installing programs

---

Before installing Smart DLogger Program, check the setting of PC environment. The system requirements may be changed depending upon the O/S of user’s PC. Smart DLogger Program supports Windows 7 32/64bit O/S and service pack 1.

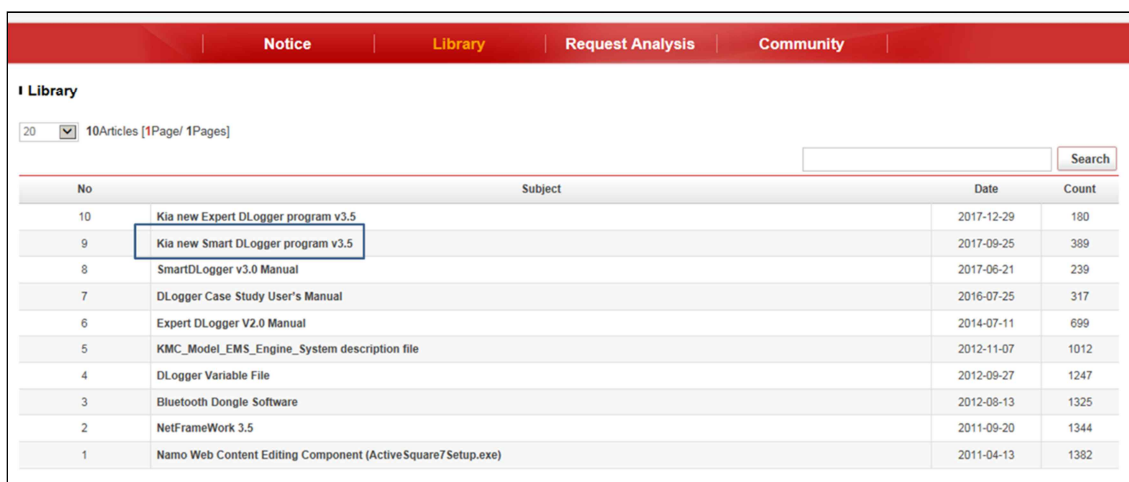
### 2.2 Installing Smart DLogger Program

---

For installation of Smart DLogger Program, log in the site of <https://dlogger.kia.com/>; Downloaded program is compressed; decompress the file and run the execution file, SmartDLogger\_v3.5.0.0.exe.

Fig. 2-1 Downloading Smart DLogger Program

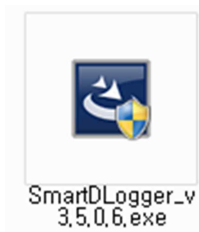
1) Download Smart DLogger Program from Library and install it.



No	Subject	Date	Count
10	Kia new Expert DLogger program v3.5	2017-12-29	180
9	Kia new Smart DLogger program v3.5	2017-09-25	389
8	SmartDLogger v3.0 Manual	2017-06-21	239
7	DLogger Case Study User's Manual	2016-07-25	317
6	Expert DLogger V2.0 Manual	2014-07-11	699
5	KMC_Model_EMS_Engine_System description file	2012-11-07	1012
4	DLogger Variable File	2012-09-27	1247
3	Bluetooth Dongle Software	2012-08-13	1325
2	NetFrameWork 3.5	2011-09-20	1344
1	Namo Web Content Editing Component (ActiveSquare7 Setup.exe)	2011-04-13	1382

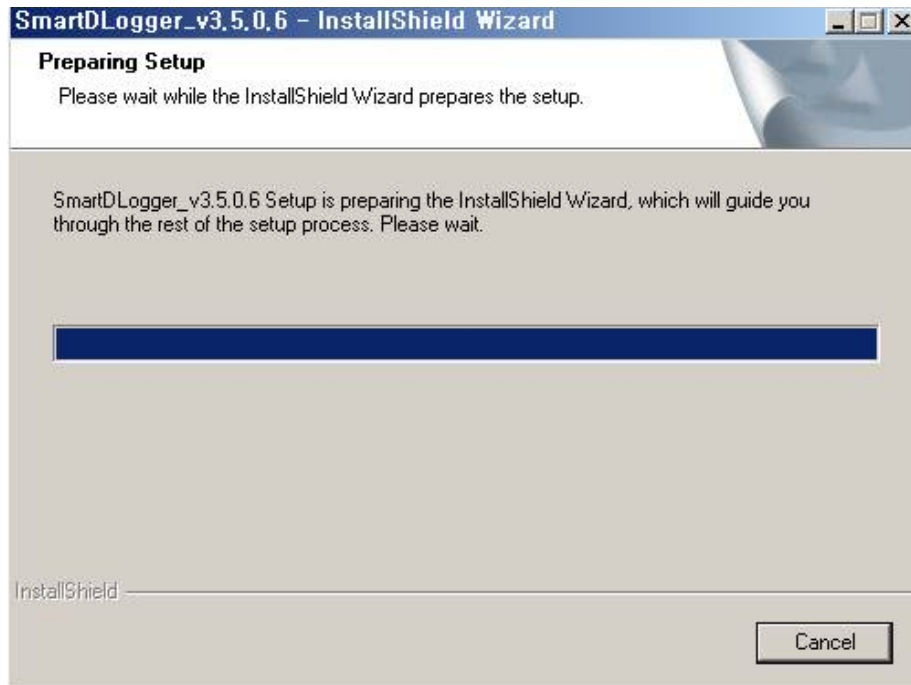
Fig. 2-2 Screen showing installation of Smart DLogger Program

1) Execution file of Smart DLogger install

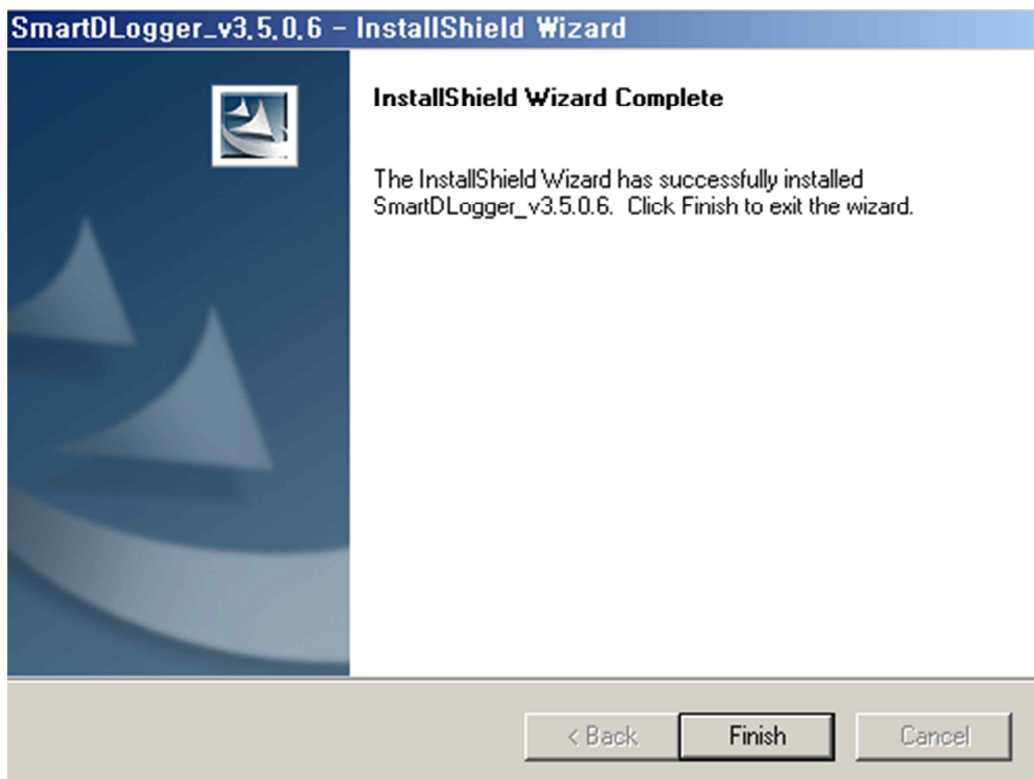


---

## 2) Executing software



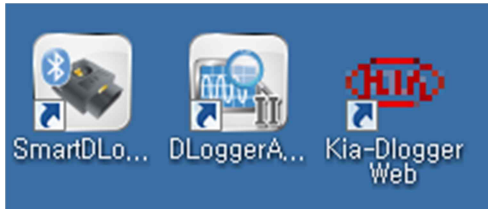
## 3) Completion of installation



---

Fig. 2-3 Icons generated after installation of Smart DLogger Program

- 1) Smart DLogger
- 2) DLogger Analyzer
- 3) Kia-Dlogger Web



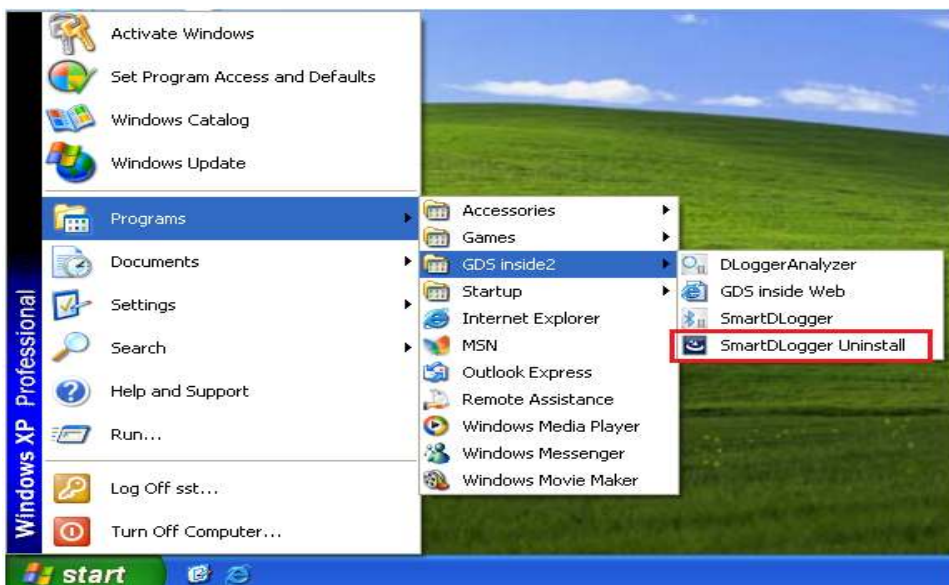
### 2.3 Deleting Smart DLogger Program

---

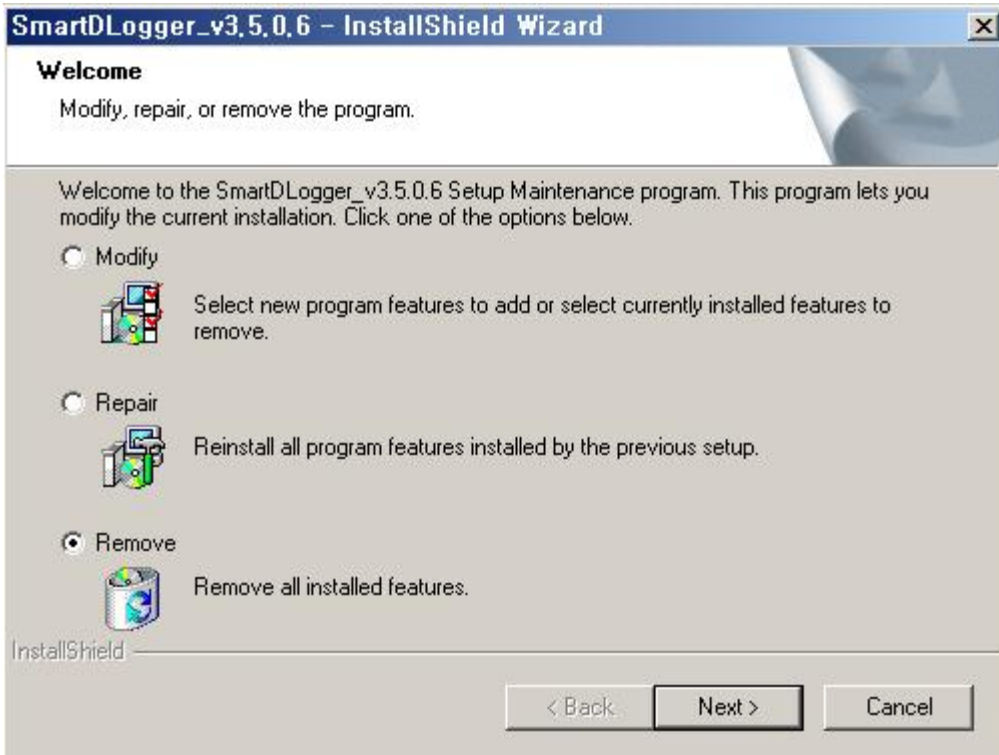
If you intend to delete Smart DLogger Program, select Start -> Program -> GDS inside2 -> Smart DLogger Uninstall.

Fig. 2-4 Screen showing deletion of Smart DLogger Program

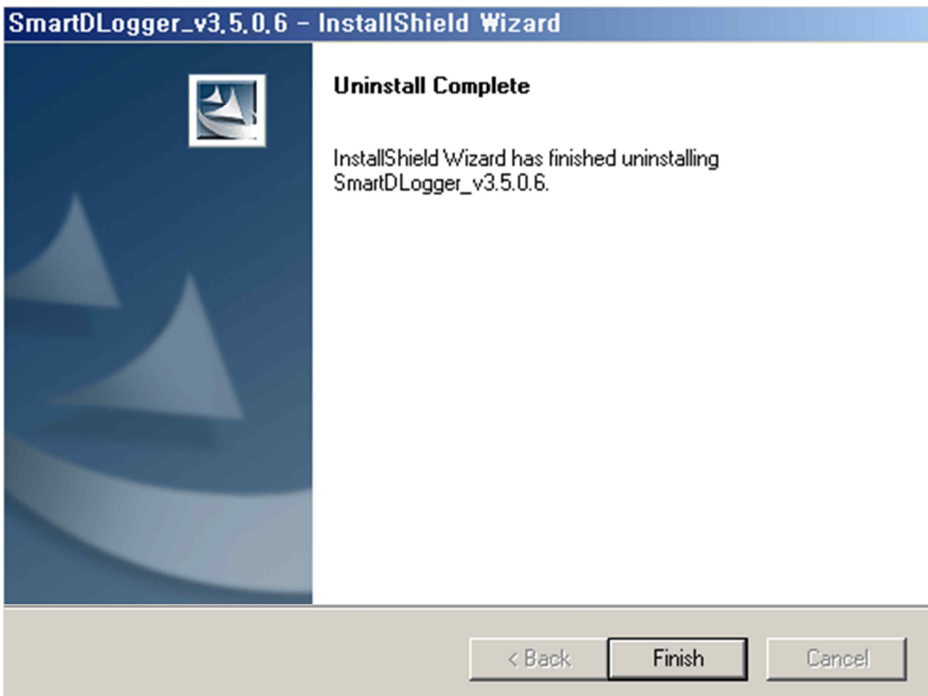
- 1) Select Start -> Program -> GDS inside2 -> Smart DLogger Uninstall.



2) Select 'Remove', then click 'Yes' for deletion.



3) Completion of deletion

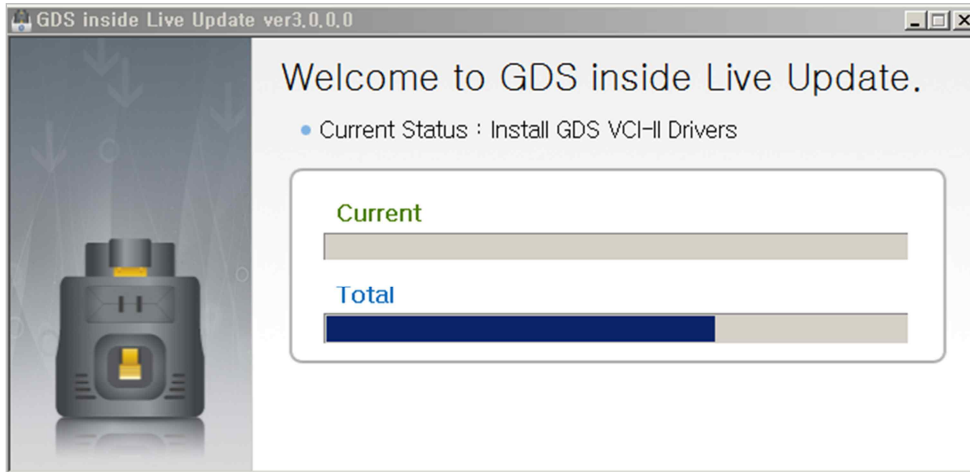


---

## 2.4 Updating Smart DLogger Program

When you run Smart DLogger Program in the state that your PC is connected with internet, the version is automatically checked and the program is updated.

Fig. 2-5 Screen showing Smart Update



## 3. Pairing Bluetooth

This part introduces all the procedures for pairing Bluetooth in PC and Smart DLogger to all users.

### 3.1 Information on concept

The communication between DLogger devices (Compact VCI, VCI-II, CVCI-II) used by Smart DLogger and PC adopts Bluetooth wireless communication. Therefore, in order to use DLogger devices, you need to pair Bluetooth once at initial step.

Fig. 3-1 Conceptual diagram of Smart DLogger communication



### 3.2 Installing a Bluetooth dongle

If no Bluetooth device is installed in PC, you may use Bluetooth dongle after installing it in an external USB.

### 3.2.1 Installing Bluetooth dongle hardware

Bluetooth dongle is included in the hardware set of Smart DLogger. If you have no Bluetooth device in your PC, you may use it after inserting it in a USB.

### 3.2.2 Installing Bluetooth dongle software

In order to install a Bluetooth dongle, you should install corresponding software. Download the software for Bluetooth dongle from Library of user site and install it.  
<https://dlogger.kia.com> -> Library -> Bluetooth Dongle Software

Fig. 3-2 Downloading Bluetooth dongle software

1) Download Bluetooth dongle software from Library of user site and install it.



No	Subject	Date	Count
10	Kia new Expert DLogger program v3.5	2017-12-29	180
9	Kia new Smart DLogger program v3.5	2017-09-25	389
8	SmartDLogger v3.0 Manual	2017-06-21	239
7	DLogger Case Study User's Manual	2016-07-25	317
6	Expert DLogger V2.0 Manual	2014-07-11	699
5	KMC_Model_EMS_Engine_System description file	2012-11-07	1012
4	DLogger Variable File	2012-09-27	1247
3	Bluetooth Dongle Software	2012-08-13	1325
2	NetFrameWork 3.5	2011-09-20	1344
1	Namo Web Content Editing Component (ActiveSquare7 Setup.exe)	2011-04-13	1382

Fig. 3-3 Screen showing installation of Bluetooth dongle software

1) Executing Bluetooth dongle software

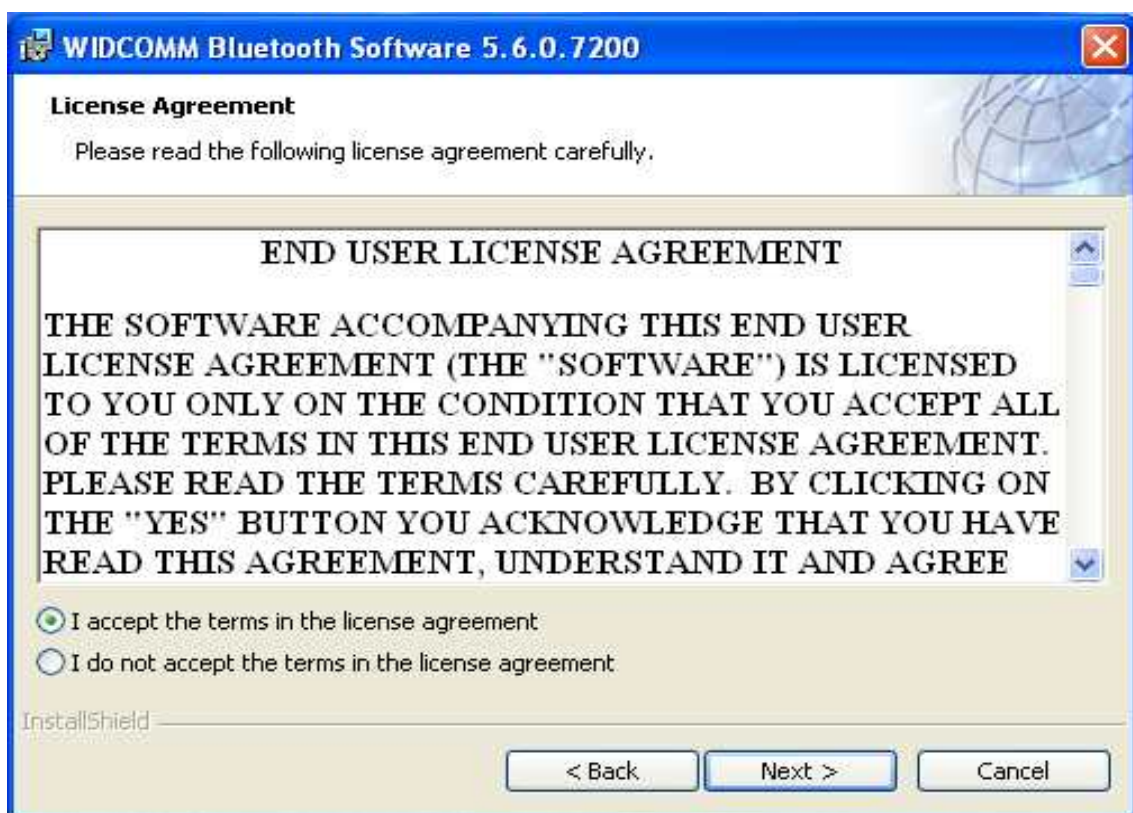




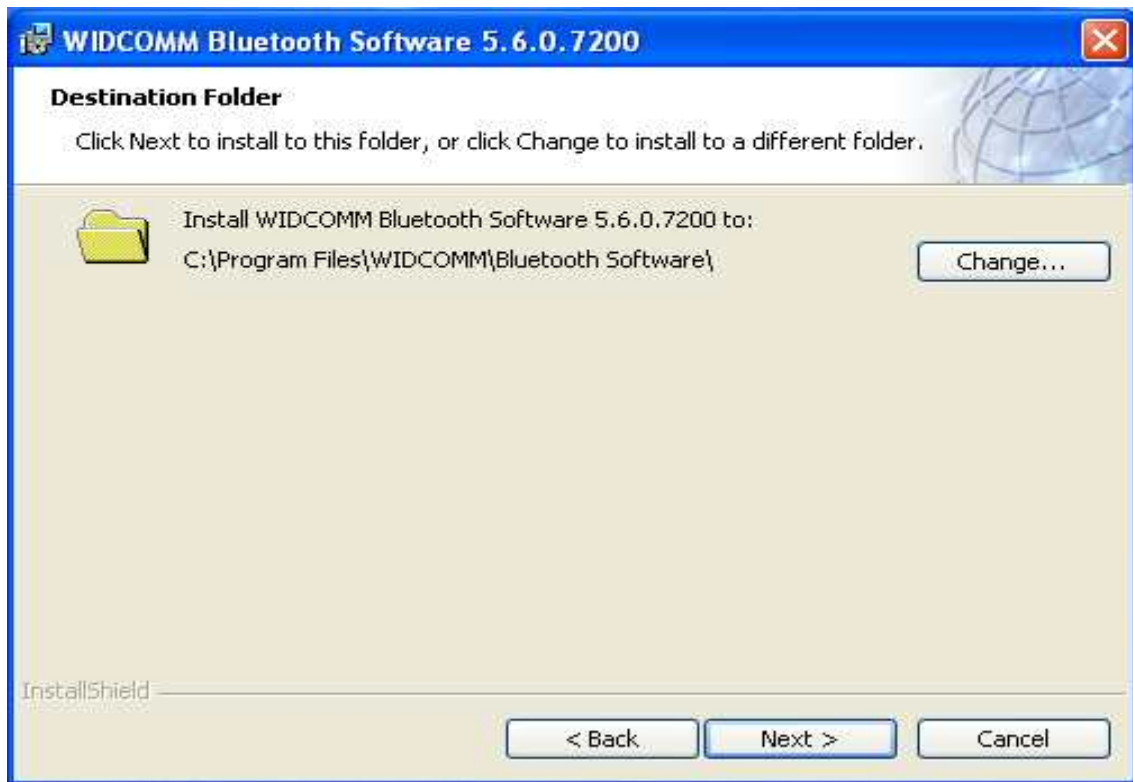
2) Next execution



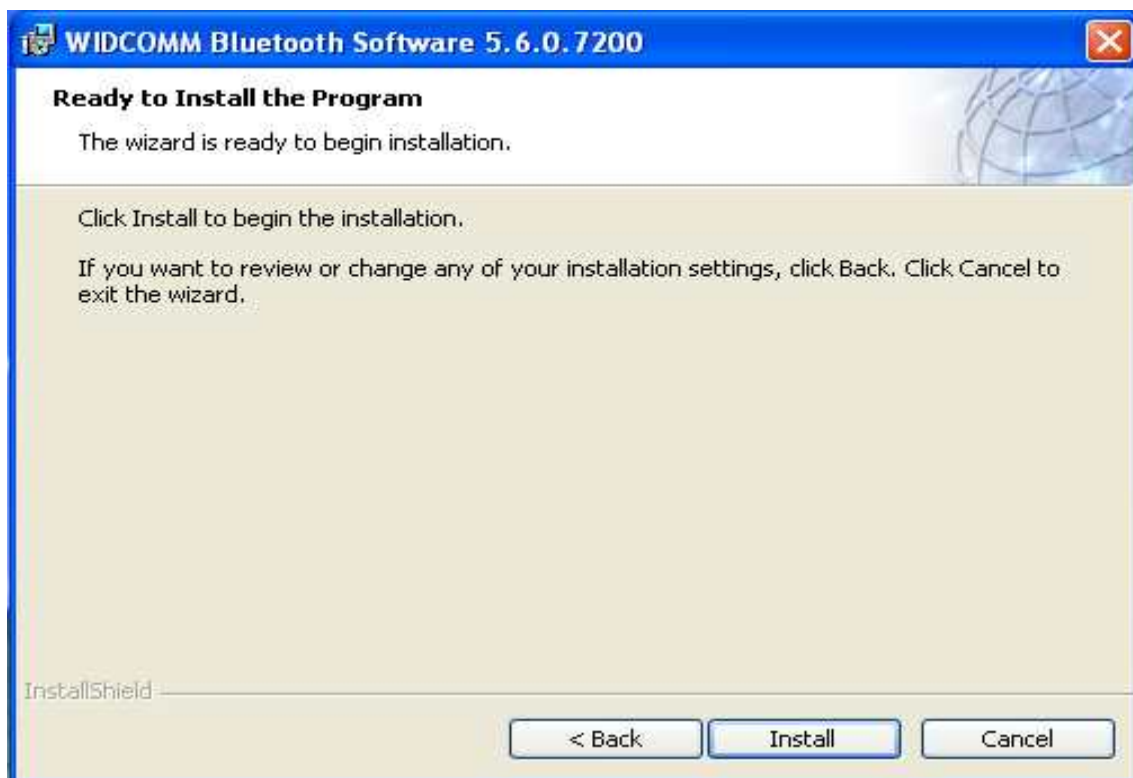
3) Agreeing in the Agreement on the Right for Use



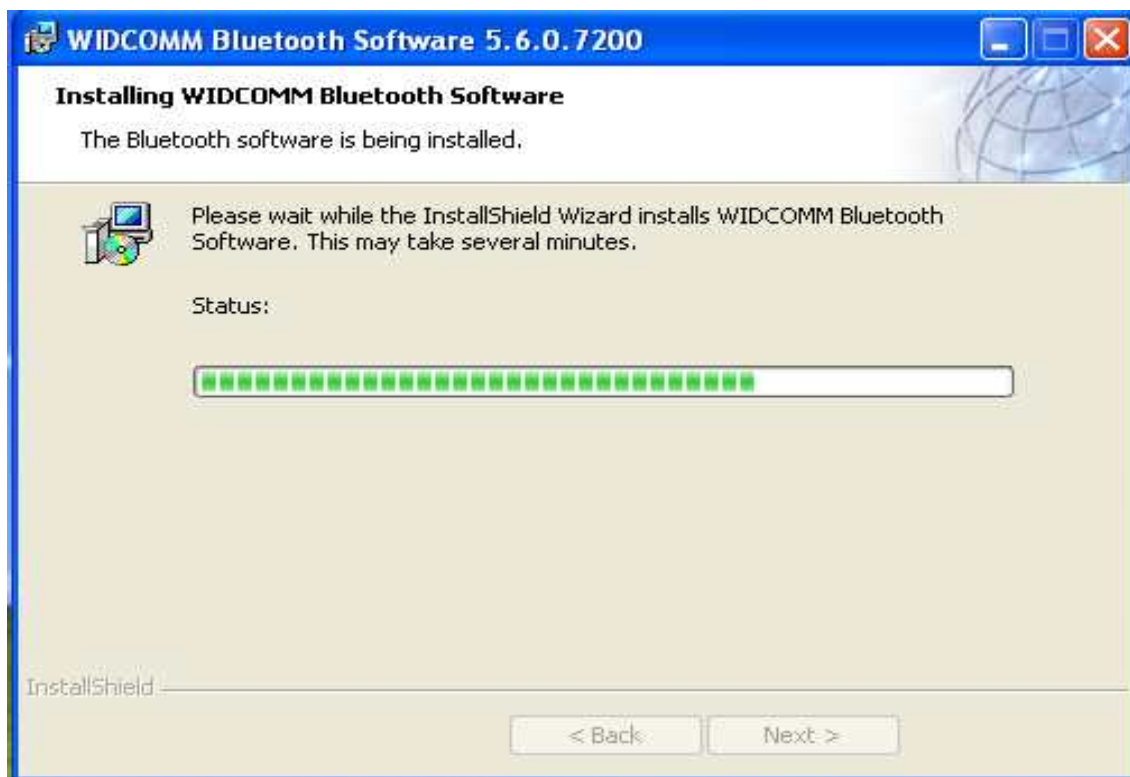
4) Next execution



5) Installing



6) Under installation



7) Completion of installation



---

### 3.3 Pairing Compact VCI Bluetooth

---

This part introduces the detailed method of Bluetooth pairing for Compact VCI.

Bluetooth program may be somewhat different depending upon the user's PC.

#### 3.3.1 Pairing Compact VCI in Smart DLogger

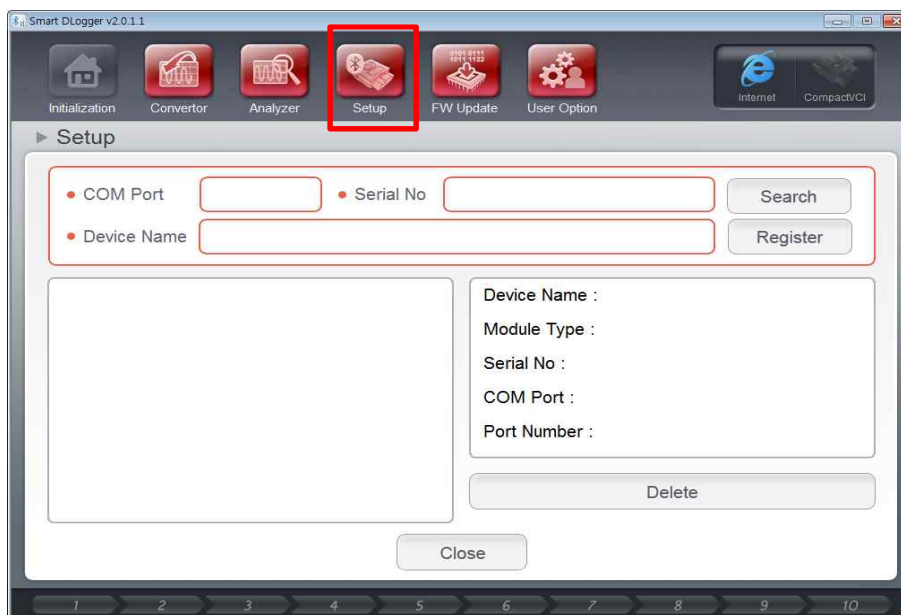
---

Open Smart DLogger Program secondly and perform Bluetooth pairing after selecting Setup in the toolbar at the top of Smart DLogger.

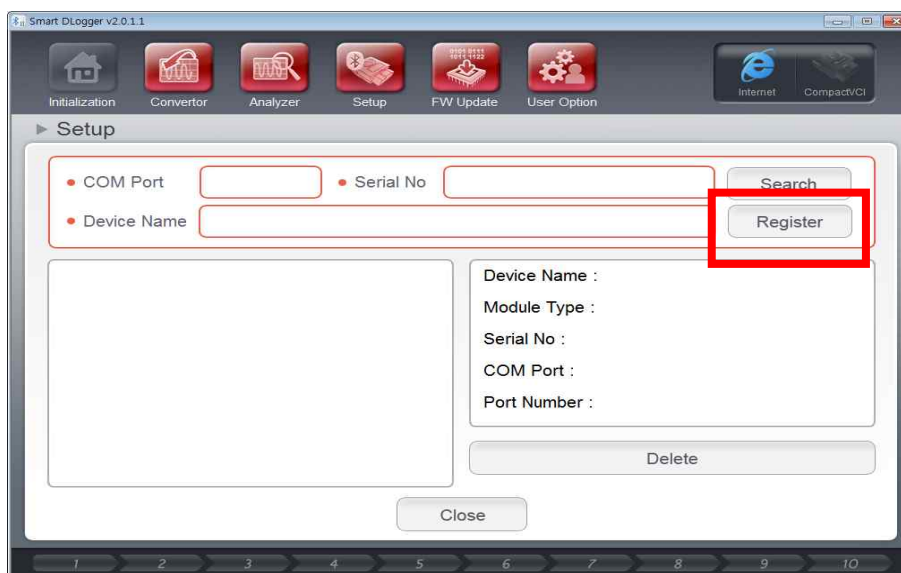
You may register Bluetooth pairing of Compact VCI in the order of Setup → Search → Register. Where, you may give a name to the device.

**Fig. 3-4 Screen showing Compact VCI pairing in Smart DLogger.**

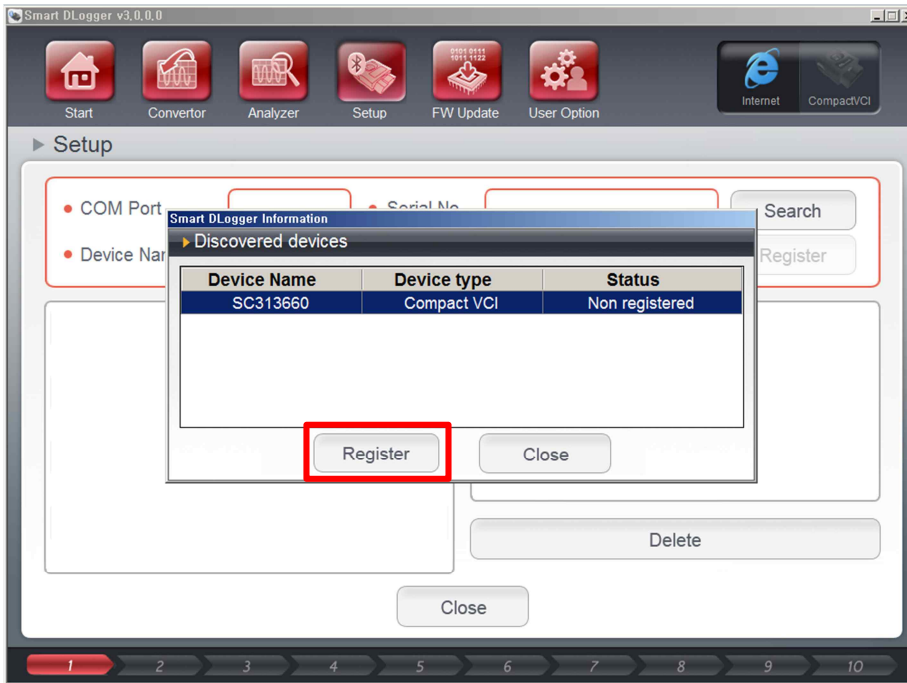
1) Select Setup of device in the toolbar at the top of Smart DLogger.



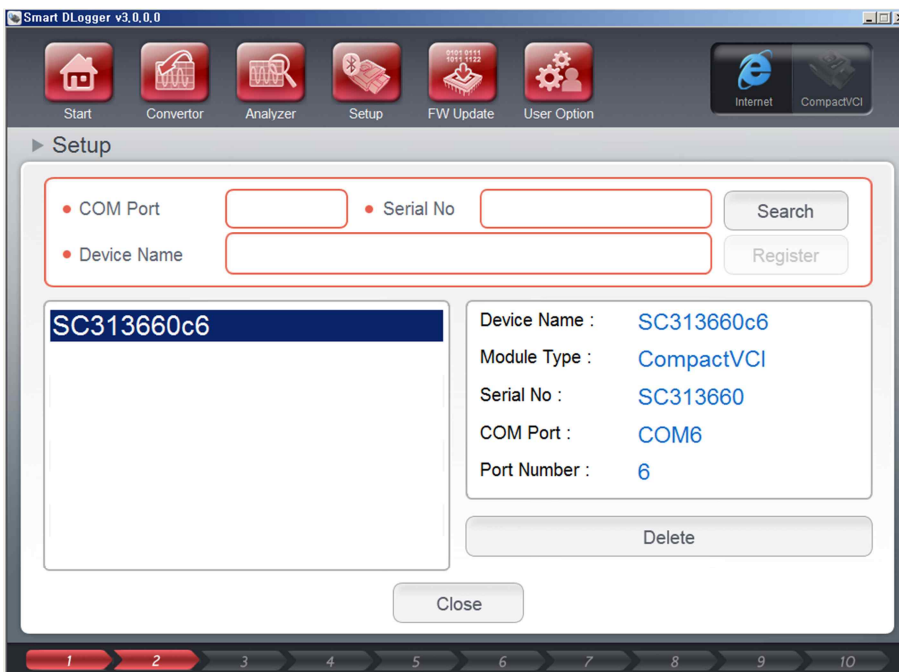
2) Click Search to search COM Port automatically.



3) Registered search device.



4) Completion of registration



3.4 Pairing Trigger Module for CVCI Bluetooth

This part introduces the detailed method of Bluetooth pairing for Trigger Module for CVCI. The case that Bluetooth pairing is needed for Trigger Module for CVCI is the case that firmware update is needed for Trigger Module for CVCI.

### 3.4.1 Pairing Trigger Module for CVCI in Smart DLogger

Open Smart DLogger Program secondly and perform Bluetooth pairing after selecting Setup in the toolbar at the top of Smart DLogger.

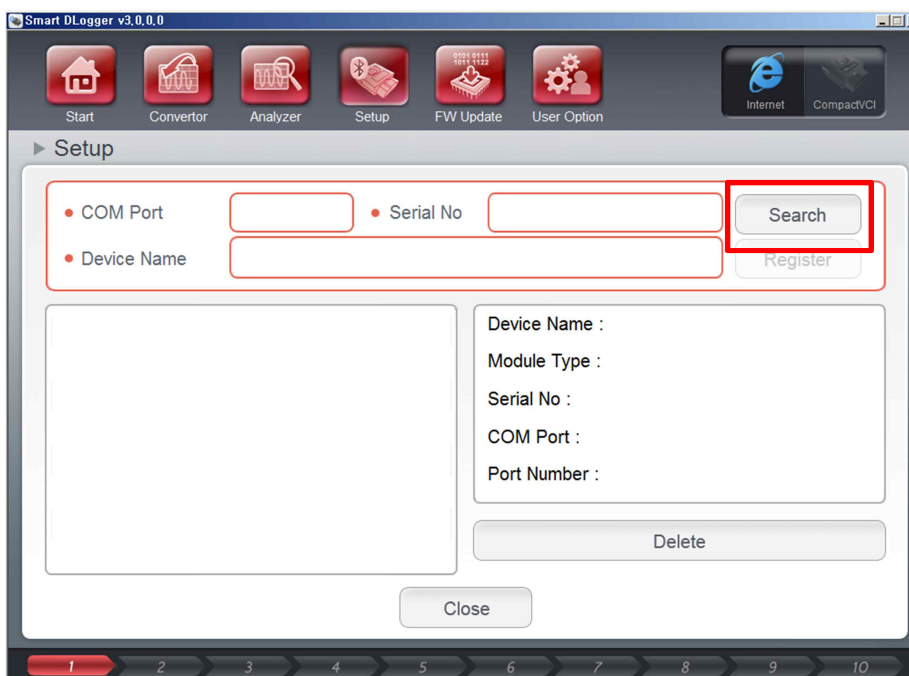
You may register Bluetooth pairing of Trigger Module for CVCI in the order of Setup → Search → Register. Where, you may give a name to the device.

**Fig. 3-5 Screen showing Trigger Module pairing in Smart DLogger.**

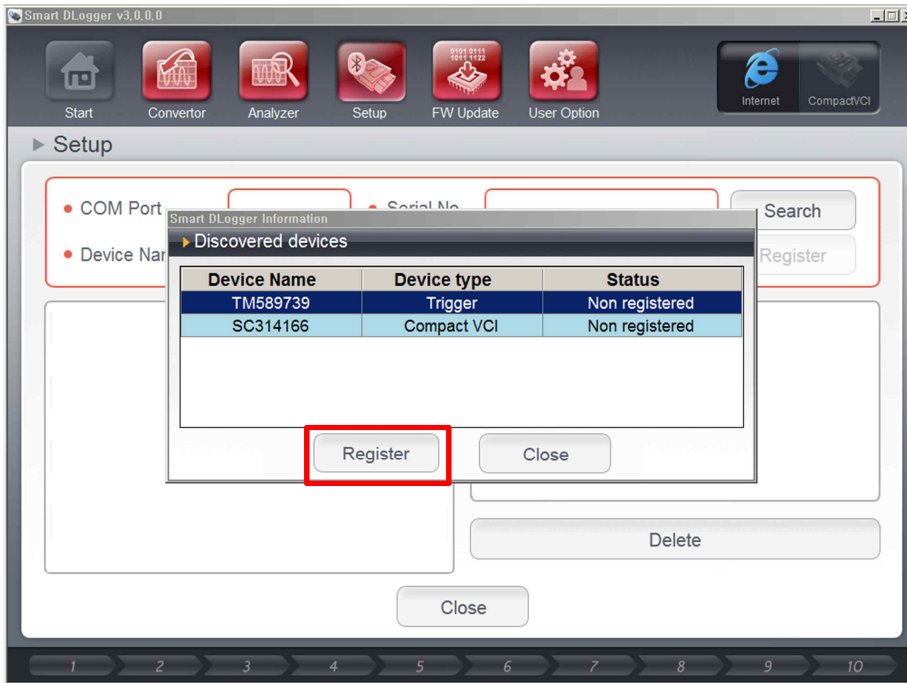
1) Select Setup of device in the toolbar at the top of Smart DLogger.



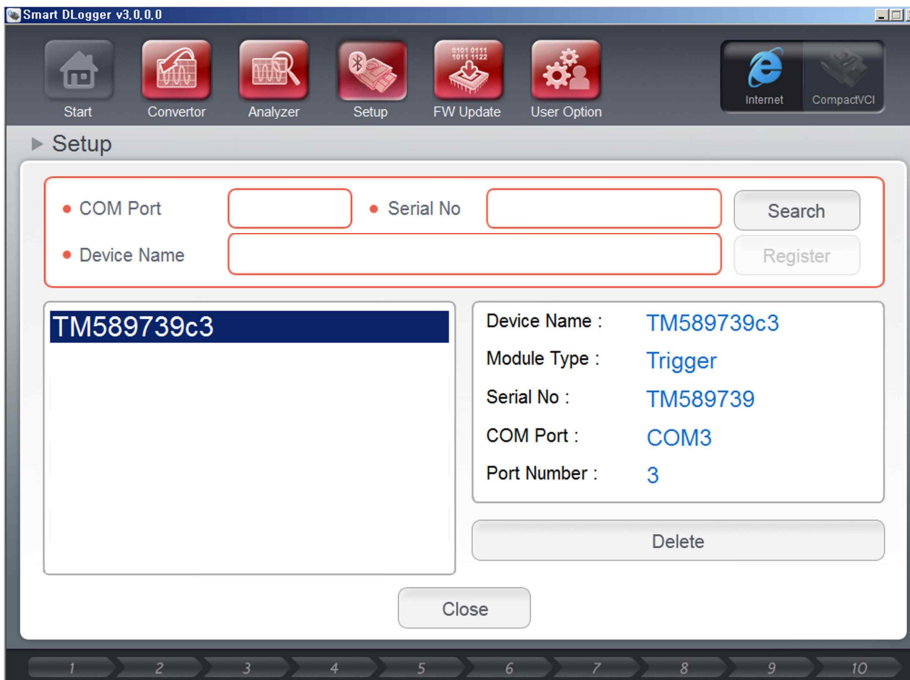
2) Click Search to search COM Port automatically.



3) Registered search device.



4) Completion of registration



---

### 3.5 Pairing Compact VCI with Trigger Module for CVCI

---

Compact VCI and Trigger Module for CVCI are paired when you purchased the equipment. This pairing is required if you want pairing again during use of the equipment or if you want pairing of the equipment that has been used mixed with other equipment.

#### 3.5.1 Pairing 1 set of Compact VCI (1:1)

---

This part introduces the method to pair one Compact VCI and one Trigger Module for CVCI 1-to-1. The method of Bluetooth pairing is as follows.

1) Put Compact VCI in OBD terminal and push the pairing switch of Compact VCI.

When setting is completed, green and red colors are turned on alternately in 1Hz.

Pairing standby mode is maintained for 60 seconds.

2) Insert Trigger Module in the cigar jack and push Enter Key of Trigger Module for CVCI for 5 seconds or longer.

Beep sound is heard, Enter Key is changed to orange color (if both green and red colors are turned on), and LED of VCI2 is rapidly changed to red alternately.

When Compact VCI to be paired is searched, CAN1 of VCI1 is changed to green; search the second Compact VCI.

When try paring for 20-second, a sound is heard and original state is restored. (Although search is completed, search state is maintained for 20 seconds.)

3) If CAN1 is not changed to green, it means pairing failure and the processes of 1 and 2 should be repeated.

4) If the process is completed, disconnect and connect the power for Compact VCI and Trigger Module for CVCI.



Fig. 3-6 CVCI paring switch



Fig. 3-7 Trigger Module for CVCI LED



---

### 3.5.2 Pairing 2 sets of Compact VCI (1:2)

---

This part introduces the method to pair two Compact VCI and one Trigger Module for CVCI 1-to-2. The method of Bluetooth pairing is as follows.

- 1) Put Compact VCI in OBD terminal and push the pairing switch of Compact VCI.  
When setting is completed, green and red colors are turned on alternately in 1Hz.  
Pairing standby mode is maintained for 60 seconds.
- 2) Insert Trigger Module in the cigar jack and push Enter Key of Trigger Module for CVCI for 5 seconds or longer.  
Beep sound is heard, Enter Key is changed to orange color (if both green and red colors are turned on), and LED of VCI2 is rapidly changed to red alternately.  
When the first Compact VCI to be paired is searched, CAN1 of VCI1 is changed to green.
- 3) Where, take out the first Compact VCI, insert the second Compact VCI in OBD terminal, and push the pairing switch of Compact VCI When Trigger Module for CVCI searches 2 CVCI, CAN2 is changed to green.  
When try pairing for 20-second, a sound is heard and original state is restored. (Although search is completed, search state is maintained for 20 seconds.)
- 4) If CAN1 and CAN2 are not changed to green, it means pairing failure and the processes of 1 and 2 should be repeated.
- 5) If the process is completed, disconnect and connect the power for Compact VCI and Trigger Module for CVCI.

---

### 3.6 Pairing VCI-II Bluetooth

---

Open Smart DLogger Program secondly and perform Bluetooth pairing after selecting Setup in the toolbar at the top of Smart DLogger.

You may register Bluetooth pairing of VCI-II in the order of Setup -> Search -> Register. Refer to “3.3 Pairing Compact VCI Bluetooth”

### 3.7 Pairing VCI-II with Trigger Module for VCI-II

---

VCI-II and Trigger Module for VCI-II are paired when you purchased the equipment. This pairing is required if you want pairing again during use of the equipment or if you want pairing of the equipment that has been used mixed with other equipment.

The method of Bluetooth pairing is as follows.

- 1) Put VCI-II in OBD terminal and push the pairing switch of VCI-II.

When setting is completed, green and red colors are turned on alternately in 1Hz. Pairing standby mode is maintained for 60 seconds.

- 2) Insert Trigger Module in the cigar jack and push Enter Key of Trigger Module for 5 seconds or longer.

Beep sound is heard, Enter Key is changed to green and red colors are changed, and LED of A row and B row is rapidly changed to red alternately.

When VCI-II to be paired is searched, VCI II of A is changed to green; search the second VCI-II.

When try paring for 20-second, a sound is heard and original state is restored.

(Although search is completed, search state is maintained for 20 seconds.)

- 3) If VCI II is not changed to green, it means pairing failure and the processes of 1), 2) should be repeated.

- 4) If the process is completed, disconnect and connect the power for VCI-II and Trigger Module.

Fig. 3-8 VCI-II Paring switch



Fig. 3-9 Trigger Module for VCI-II LED



---

### 3.8 Pairing CVCI-II Bluetooth

Open Smart DLogger Program secondly and perform Bluetooth pairing after selecting Setup in the toolbar at the top of Smart DLogger.

You may register Bluetooth pairing of CVCI-II in the order of Setup -> Search -> Register. Refer to “3.3 Pairing Compact VCI Bluetooth”

### 3.9 Pairing CVCI-II with Trigger Module for CVCI-II

CVCI-II and Trigger Module for CVCI-II are paired when you purchased the equipment. This pairing is required if you want pairing again during use of the equipment or if you want pairing of the equipment that has been used mixed with other equipment. The method of Bluetooth pairing is refer to “3.7 Pairing VCI-II with Trigger Module for VCI-II”.

**Fig. 3-10 CVCI-II Pairing switch**



**Fig. 3-11 Trigger Module for CVCI-II LED**



---

## 4. Updating firmware

---

### 4.1 Compact VCI firmware

---

In case of Compact VCI, it is needed to improve the operational functions of communication or data recording, etc. or additional functions are generated, you need to update firmware.

#### 4.1.1 Automatic firmware

---

If you use Smart DLogger Program after pairing Compact VCI and if the firmware of Compact VCI is updated, the version of firmware is automatically checked and firmware is automatically updated before generating an event file.

#### 4.1.2 Manual firmware

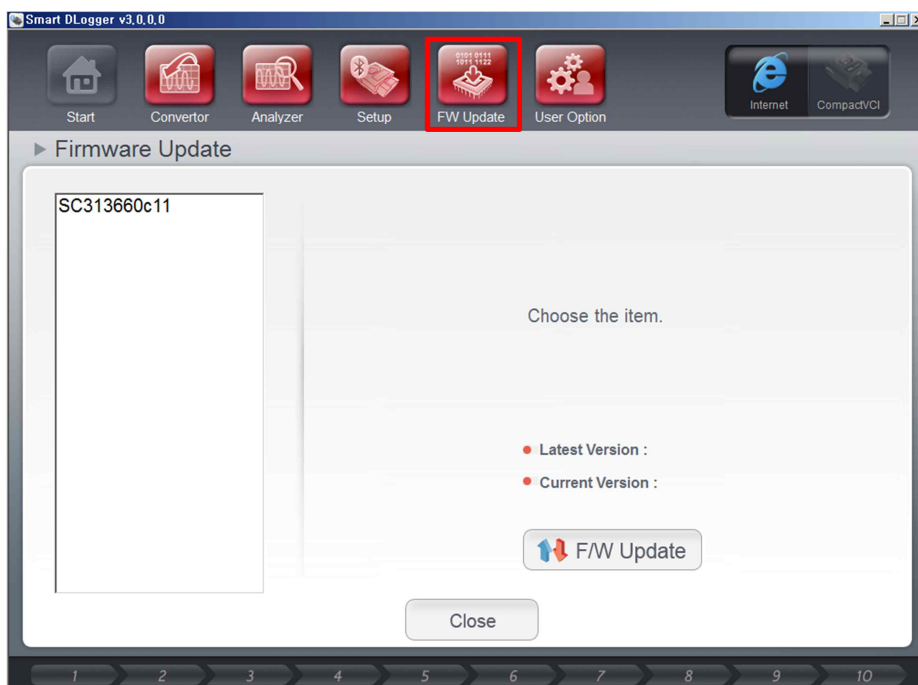
---

You may open Smart DLogger Program in the mode that you want to update the firmware manually and you may update firmware of Compact VCI after selecting FW Update in the toolbar at the top of Smart DLogger.

For updating the firmware, Compact VCI to be updated should be paired. For pairing method, refer to “3.3 Pairing Compact VCI Bluetooth.”

Fig. 4-1 Compact VCI firmware

1) Select FW Update in the toolbar at the top of Smart DLogger.



---

## 2) Update Compact VCI firmware.



### 4.2 Trigger Module for CVCI firmware

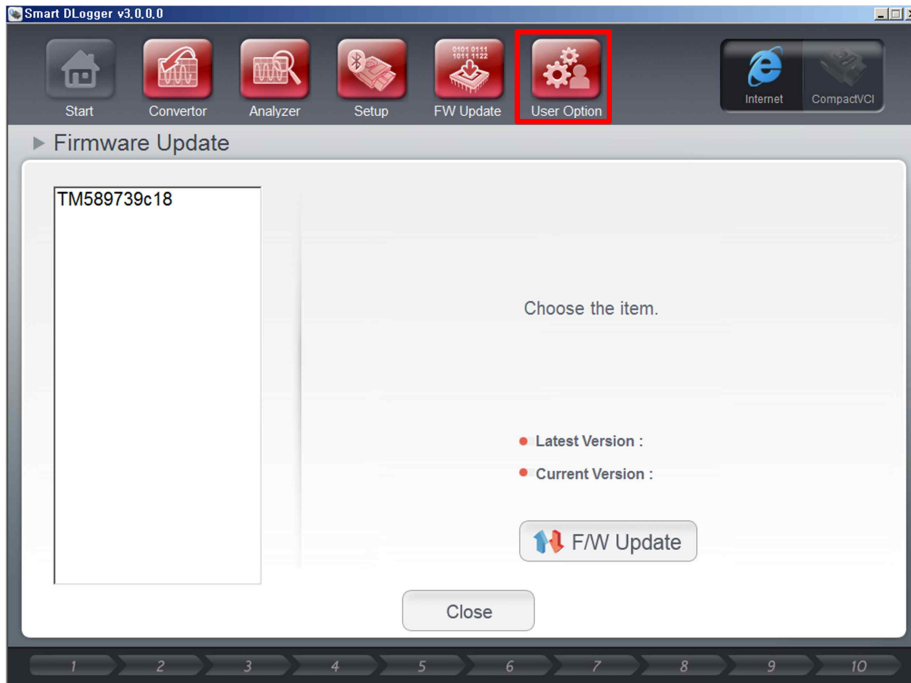
---

In case of Trigger Module for CVCI, if the functions of operation to be improved or additional functions are generated, you should update the firmware. If the functions are updated, notification of update appears through Smart DLogger Program and user site and then you should update the firmware manually. You may open Smart DLogger Program and may update the firmware of Trigger Module for CVCI after selecting FW Update in the toolbar at the top of Smart DLogger

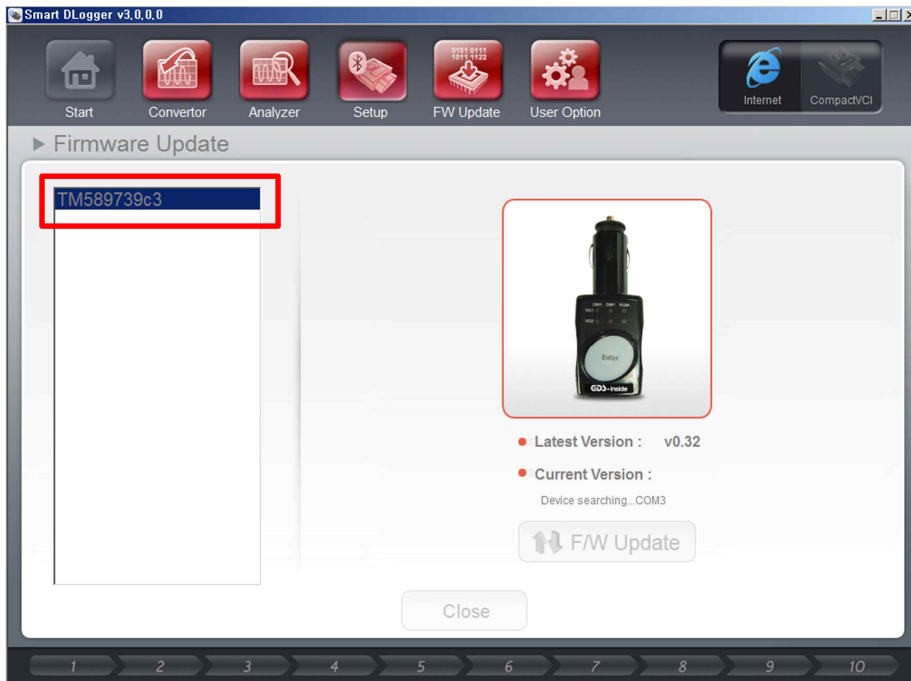
For updating the firmware, Trigger Module for CVCI to be updated should be paired. For pairing method, refer to “3.4 Pairing Trigger Module Bluetooth.”

Fig. 4-2 Trigger Module for CVCI firmware

1) Select FW Update in the toolbar at the top of Smart DLogger.



2) Update Trigger Module firmware.





---

#### 4.3 VCI-II firmware

---

In case of VCI-II, it is needed to improve the operational functions of communication or data recording, etc. or additional functions are generated, you need to update firmware.

##### 4.3.1 Automatic firmware

---

If you use Smart DLogger Program after pairing VCI-II and if the firmware of VCI-II is updated, the version of firmware is automatically checked and firmware is automatically updated before generating an event file.

##### 4.3.2 Manual firmware

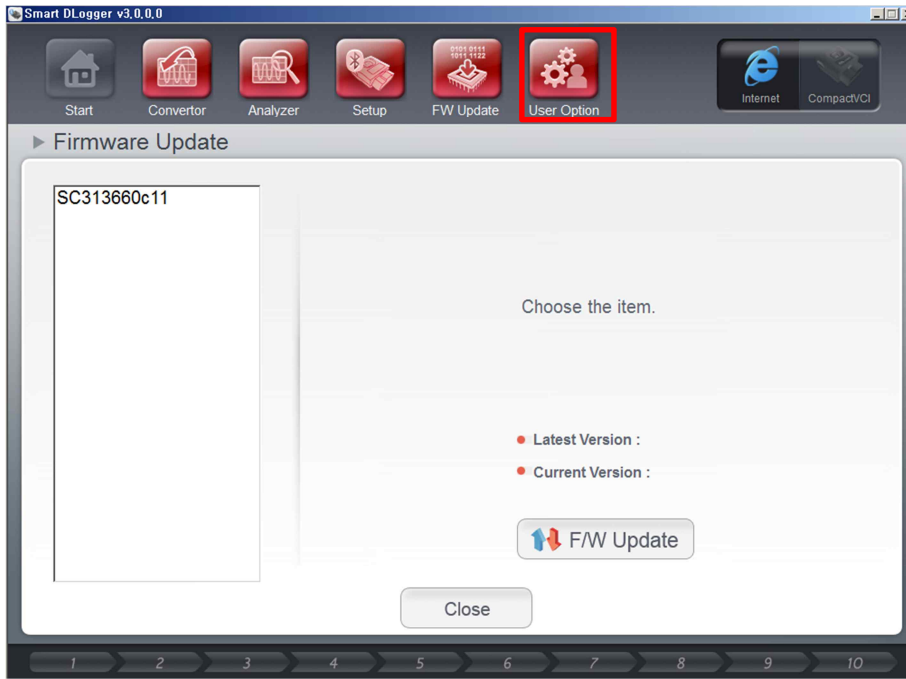
---

You may open Smart DLogger Program in the mode that you want to update the firmware manually and you may update firmware of VCI-II after selecting FW Update in the toolbar at the top of Smart DLogger.

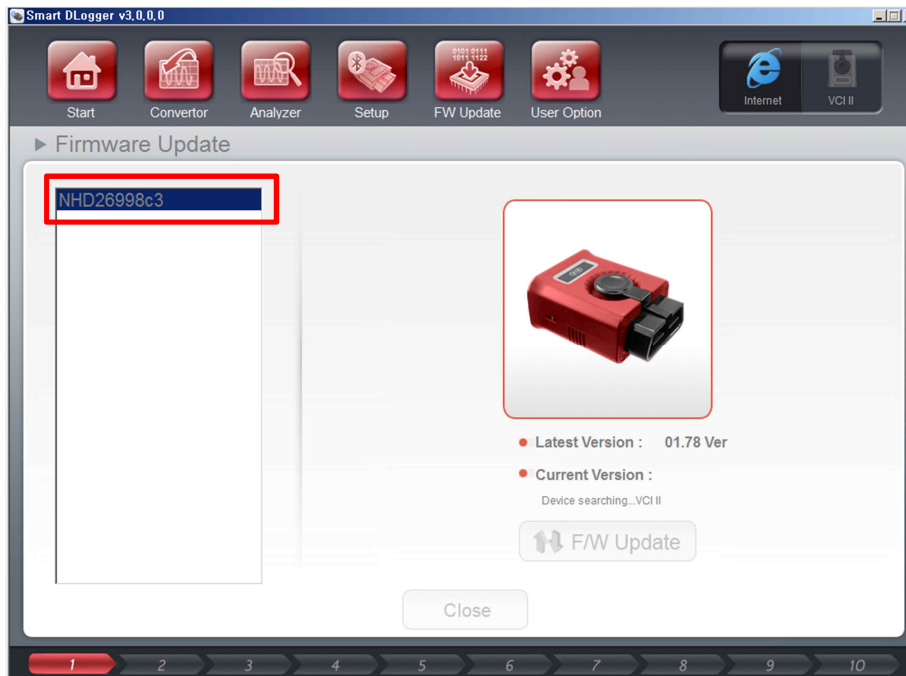
For updating the firmware, VCI-II to be updated should be paired. For pairing method, refer to “3.3 Pairing CVCI Bluetooth”

Fig. 4-3 VCI-II firmware

1) Select FW Update in the toolbar at the top of Smart DLogger.



2) Update VCI-II firmware.



---

#### 4.4 CVCI-II firmware

---

In case of CVCI-II, it is needed to improve the operational functions of communication or data recording, etc. or additional functions are generated, you need to update firmware.

##### 4.4.1 Automatic firmware

---

If you use Smart DLogger Program after pairing CVCI-II and if the firmware of CVCI-II is updated, the version of firmware is automatically checked and firmware is automatically updated before generating an event file.

##### 4.4.2 Manual firmware

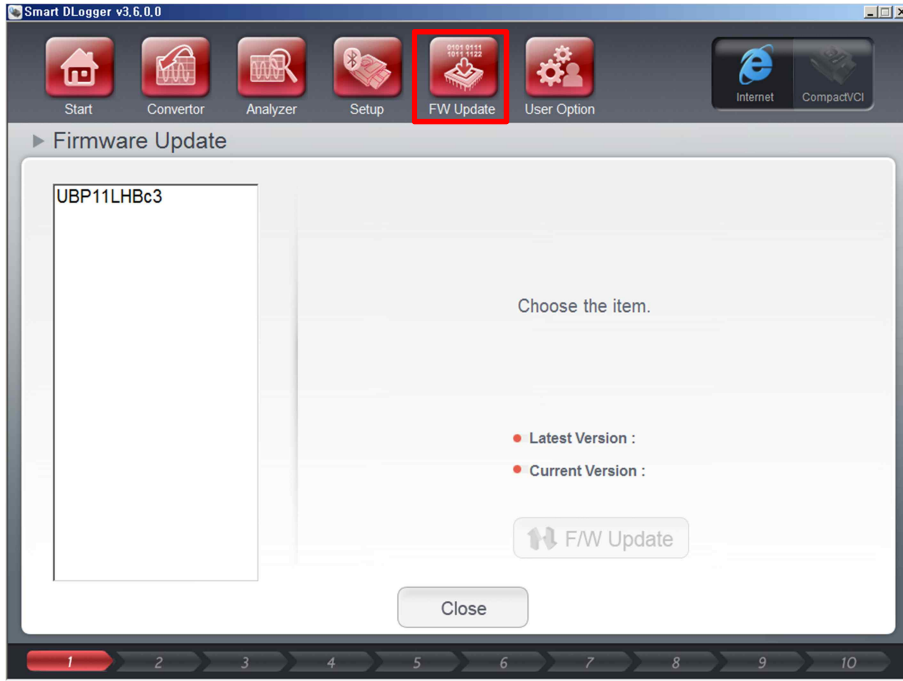
---

You may open Smart DLogger Program in the mode that you want to update the firmware manually and you may update firmware of CVCI-II after selecting FW Update in the toolbar at the top of Smart DLogger.

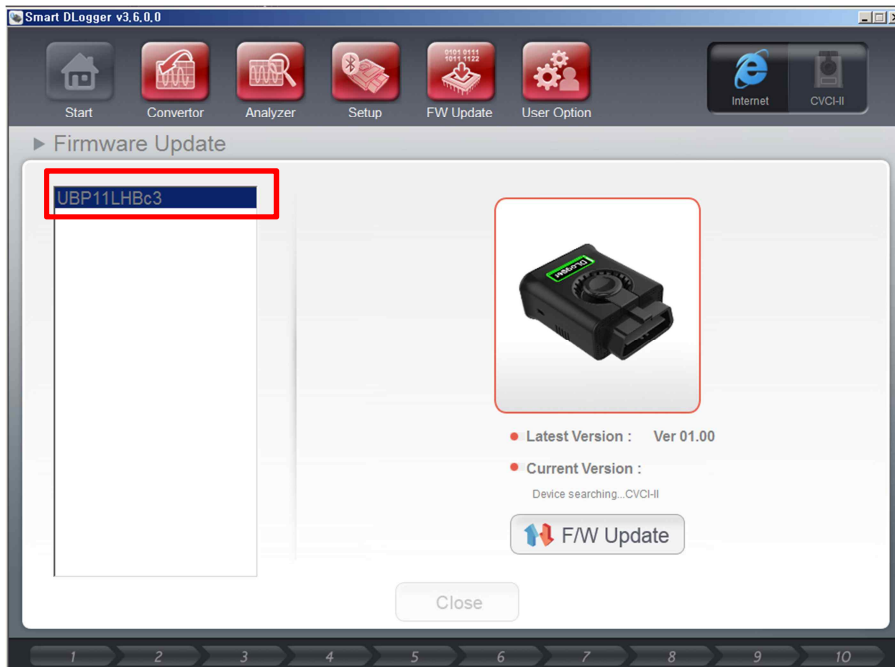
For updating the firmware, CVCI-II to be updated should be paired. For pairing method, refer to “3.6 Pairing VCI-II Bluetooth”

Fig. 4-4 CVCI-II firmware

1) Select FW Update in the toolbar at the top of Smart DLogger.



2) Update CVCI-II firmware.



---

## 5. Smart DLogger Program

---

Smart DLogger Program may be easily used by a beginner to select intended system symptom rapidly and to record high-quality data.

### 5.1 Explanation of functions

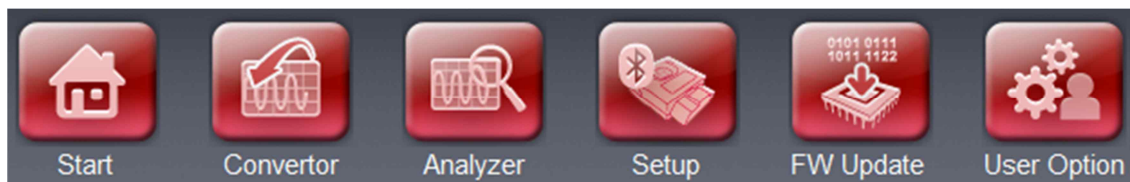
---

You may perform the whole process to set the measurement variables to meet the symptom of each system, record data, converts recorded files for analysis programming, and analyze the data, using Smart DLogger Program.

Smart DLogger may provide proper support only when internet is connected.

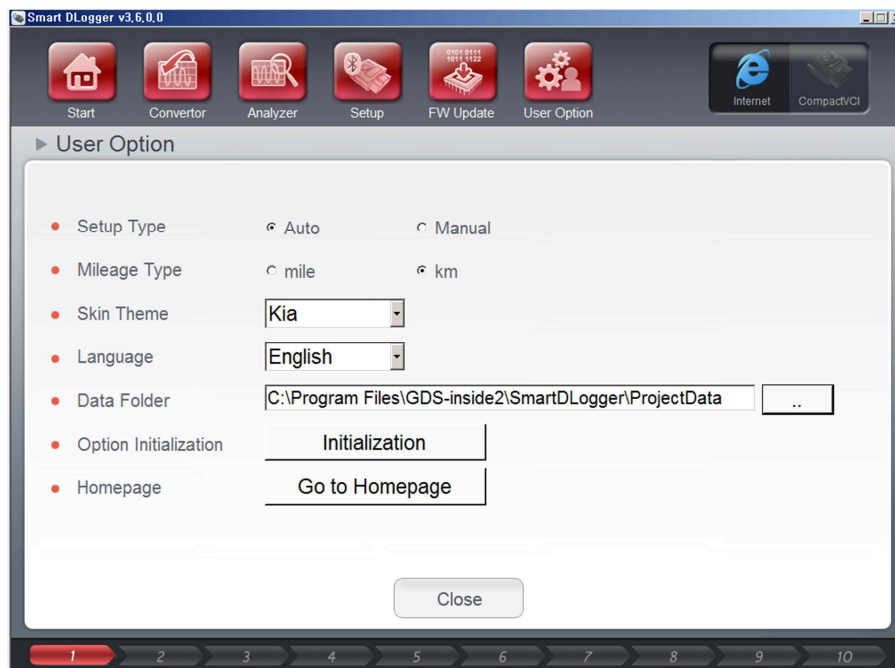
The functions in the toolbar at the top of Smart DLogger are as described below.

Fig. 5-1 Toolbar at the top of Smart DLogger



- 1) Initialization: You may go to initial screen.
- 2) Convertor: Data is converted so that you may see recorded data using an analysis program after the data is recorded.
- 3) Analyzer: It starts analysis of recorded data.
- 4) Setup: It pairs DLogger devices (Compact VCI, Trigger module for CVCI, VCI-II, CVCI-II) and store and manage corresponding information.
- 5) FW Update: It updates the firmware of DLogger devices (Compact VCI, Trigger module for CVCI, VCI-II, CVCI-II).
- 6) User Option: It supports setup type, mileage type, skin theme, language, selection of data folder position, and initialization of options.
  - \* Setup Type – Auto, Manual
  - \* Mileage Type – mile, km
  - \* Skin Theme – Kia (Red)
  - \* Language – Korean, English, Chinese, Deutsch, Español
  - \* Data Folder – C:\WProgram Files\WGDS-inside2W\SmartDLogger\WProjectData
  - \* Option Initialization – Initialization option information
  - \* Homepage – DLogger user web site link

Fig. 5-2 User Option



## 5.2 Generating events

You may generate event files to meet the system and symptom using Smart DLogger Program. Insert DLogger devices (Compact VCI, VCI-II, CVCI-II) in the OBD terminal of the vehicle and proceed the contents of instructions given by Smart DLogger Program. When the information on VIN and ROM ID and the information on the symptom you selected is sent to the server through DLogger devices (Compact VCI, VCI-II, CVCI-II), the event file is generated to meet the information and is sent to your PC in order to generate the event file in DLogger devices (Compact VCI, VCI-II, CVCI-II) through Bluetooth.

### 5.2.1 Information on events

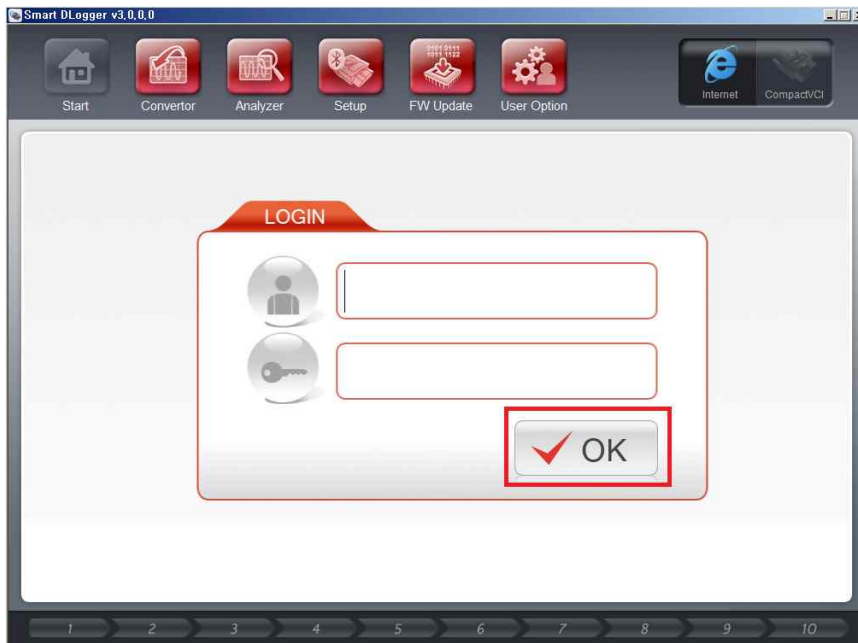
The file names of events are automatically generated in the order of date and time. Two event files (evt file and dat file) are generated: evt file has the information related with variables and dat file has the contents related with communication. (ex; 20130807053038.evt / config.dat)

### 5.2.2 Automatic generation

This function is used when a vehicle is available and you generate events after inserting DLogger devices (Compact VCI, VCI-II, CVCI-II) in the OBD terminal. DLogger devices (Compact VCI, VCI-II, CVCI-II) should be paired with PC in advance. If DLogger devices (Compact VCI, VCI-II, CVCI-II) is not paired, generate events after pairing referring to “3.3 Pairing Compact VCI Bluetooth.”

Fig. 5-3 Generation of events – Automatic setup (for example CVCI)

1) Login



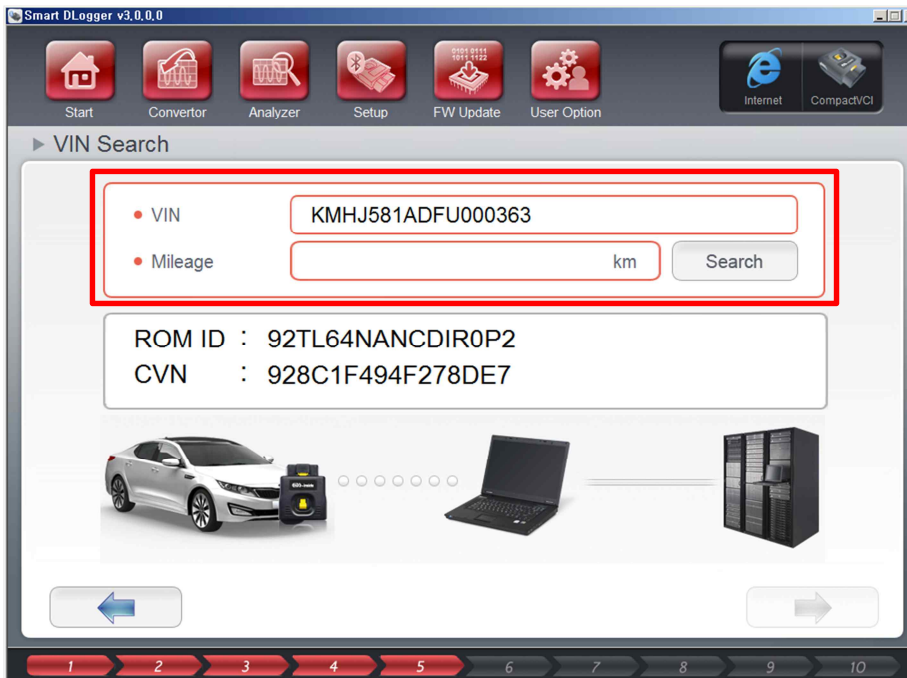
2) Insert Compact VCI in the OBD terminal and turn IG Key ON.



3) Confirm communication and IG-ON.

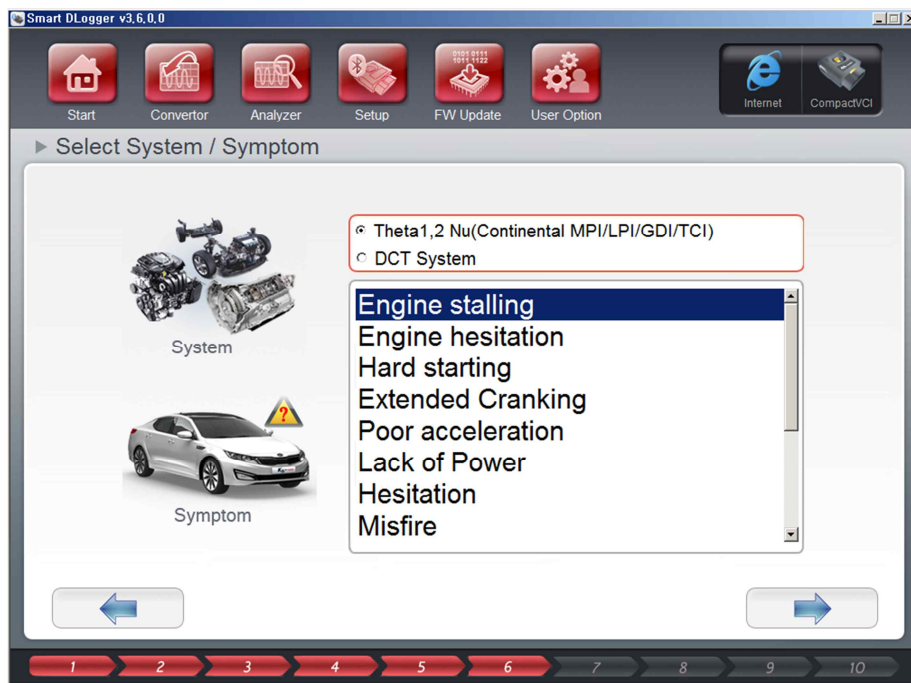


4) ROM ID and VIN is automatically searched (If VIN is not inputted, input it manually.)

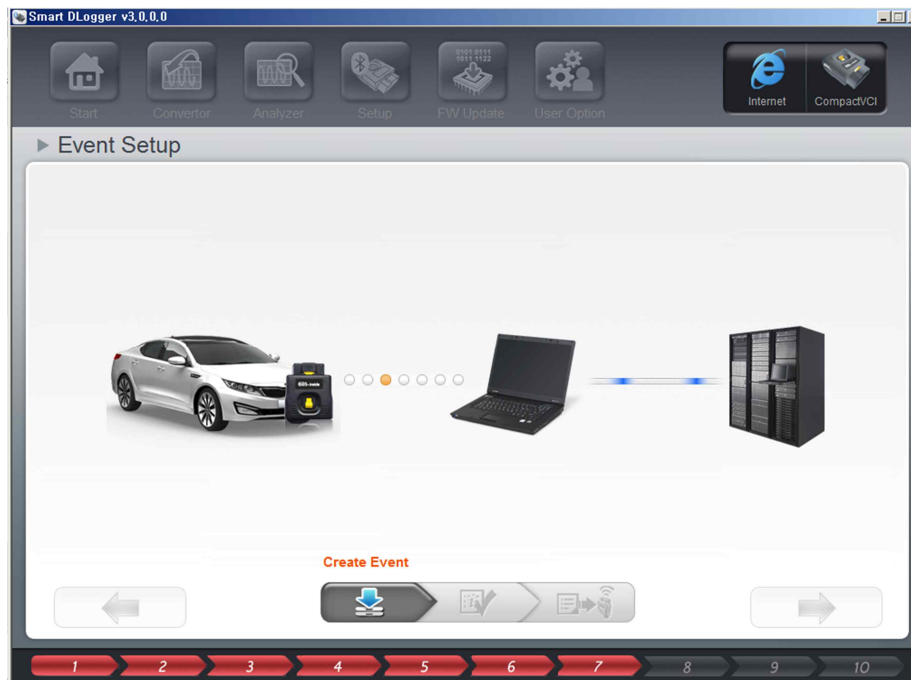




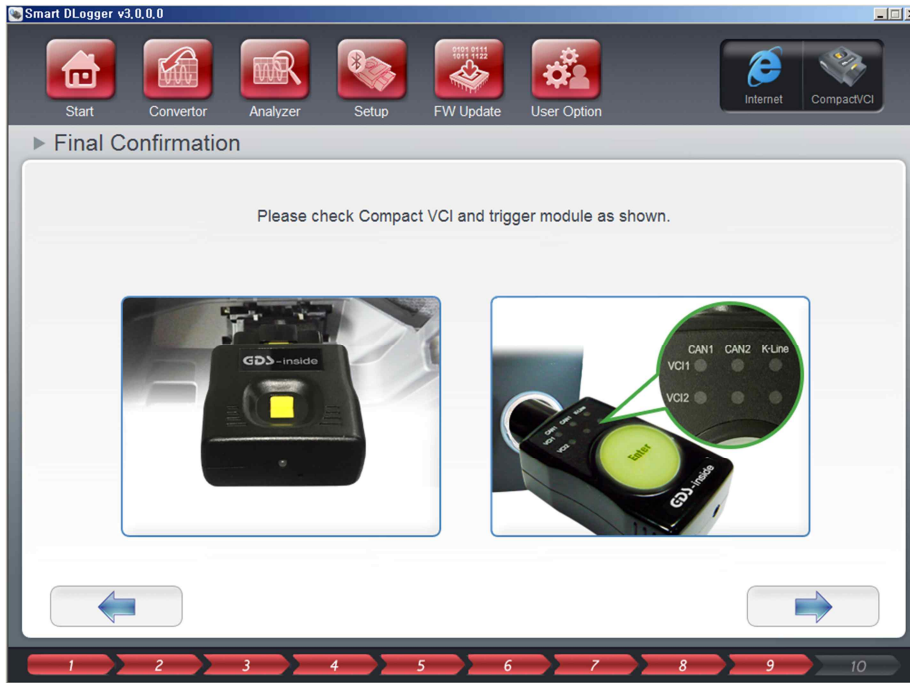
5) Select symptom.



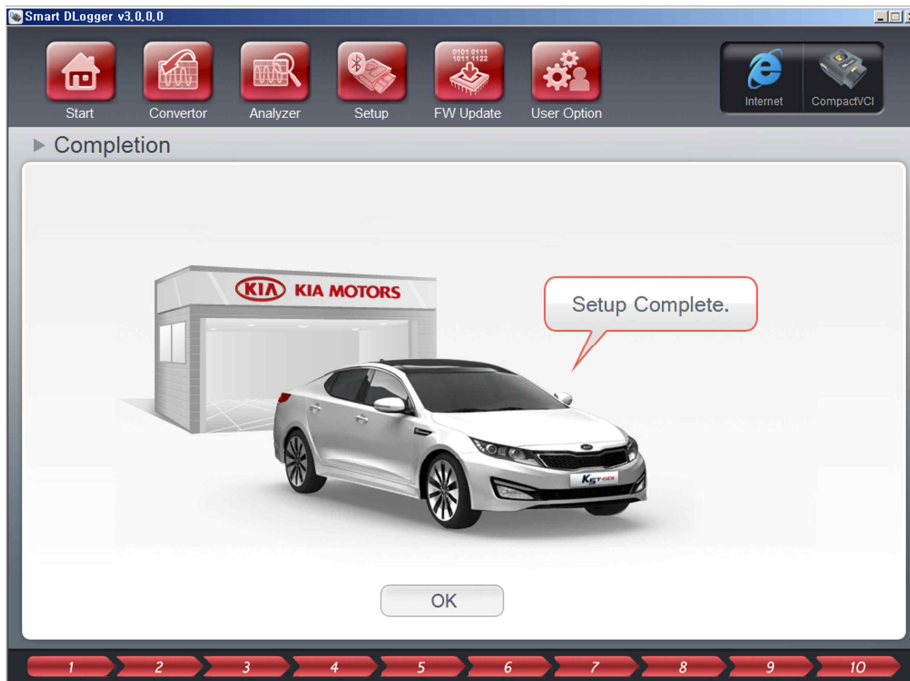
6) Generate events.



7) Insert Trigger Module in the cigar jack.



8) Completion of generation of events



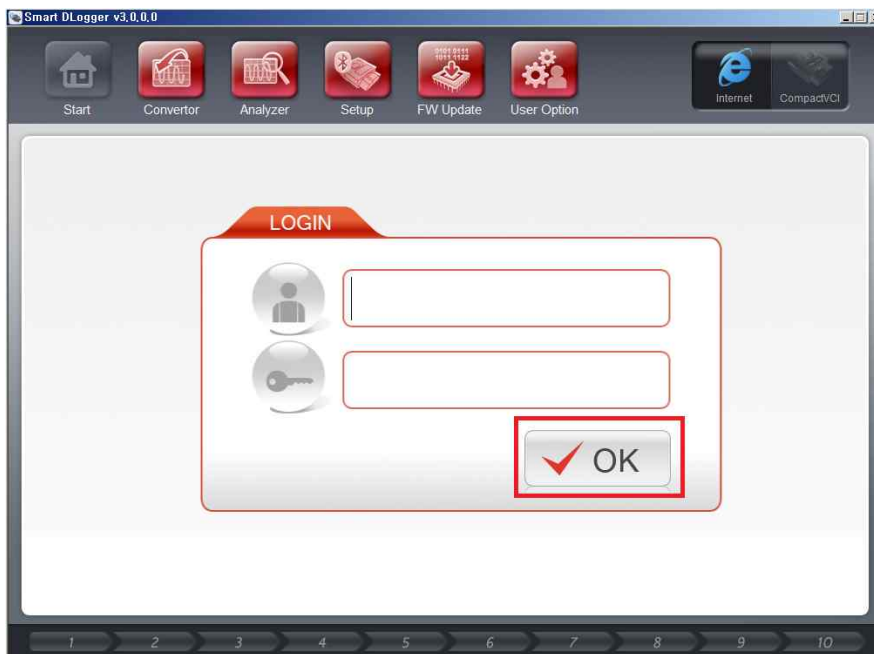
### 5.2.3 Manual generation

You may use this function if no vehicle is available and if you intend to generate and use event files only or support a far external part with event files. For this, you should know the ROM ID, VIN, and symptom of the vehicle.

You may store the event files in an intended position.

Fig. 5-4 Generation of events – Manual setup : CVCI

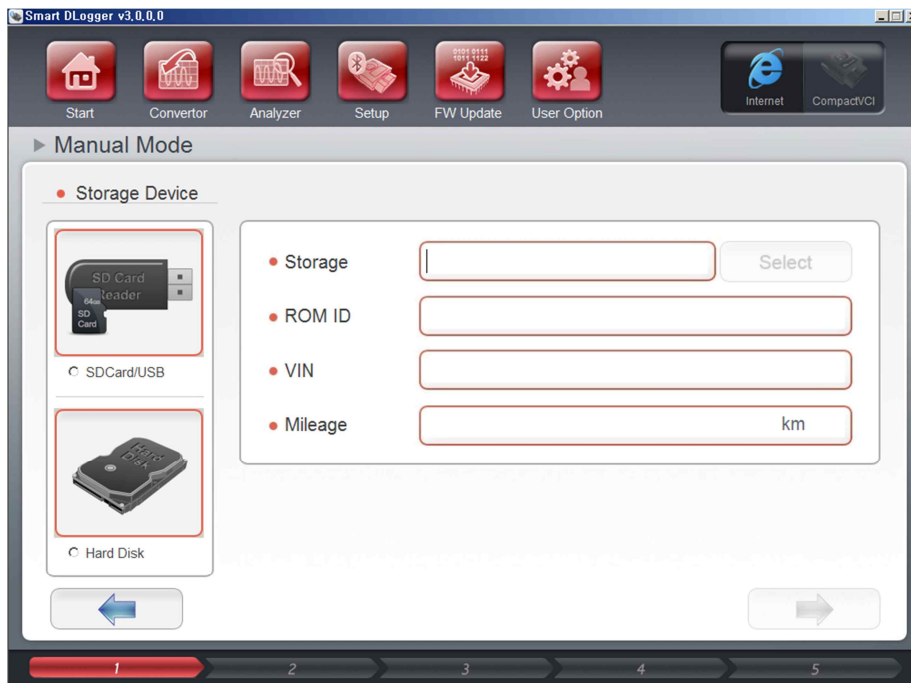
#### 1) Login



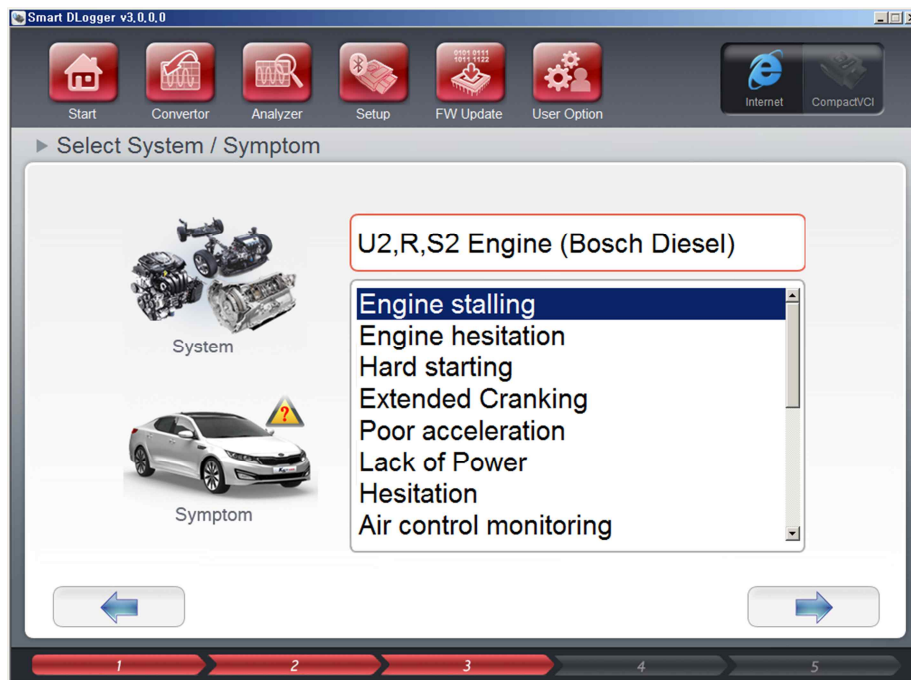
#### 2) Select CVCI.



3) Select a storage type, and inputs ROM ID, VIN and mileage.



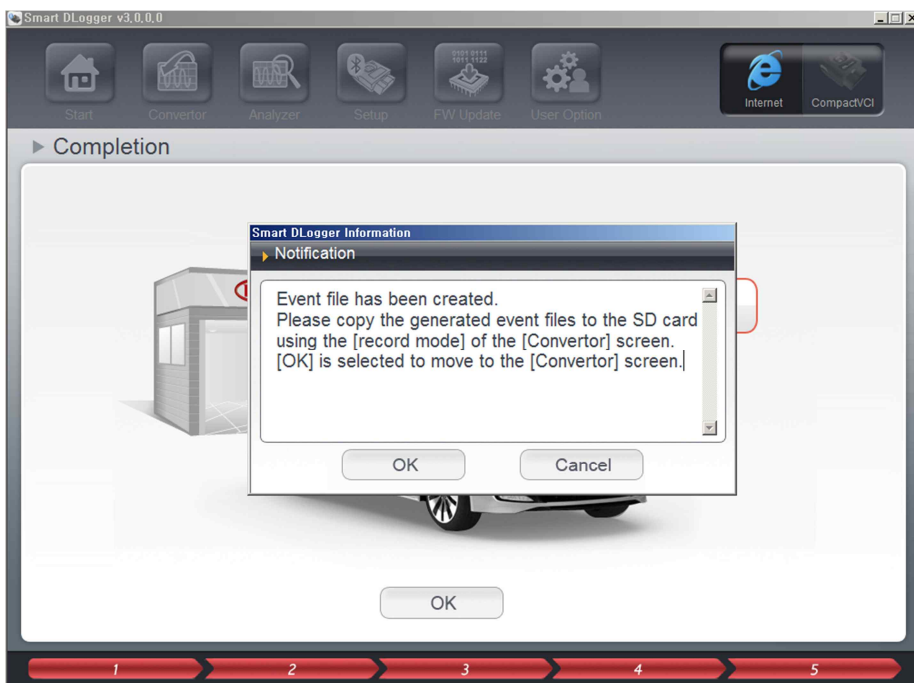
4) Select symptom.



## 5) Generation events



## 6) Confirm generated event files.



7) Completion of generation of events

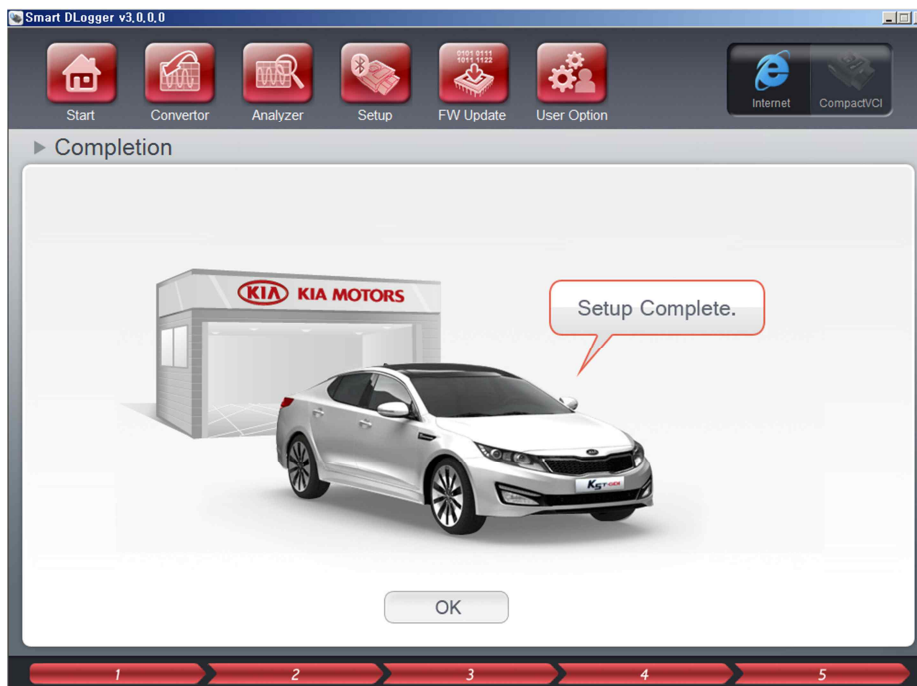
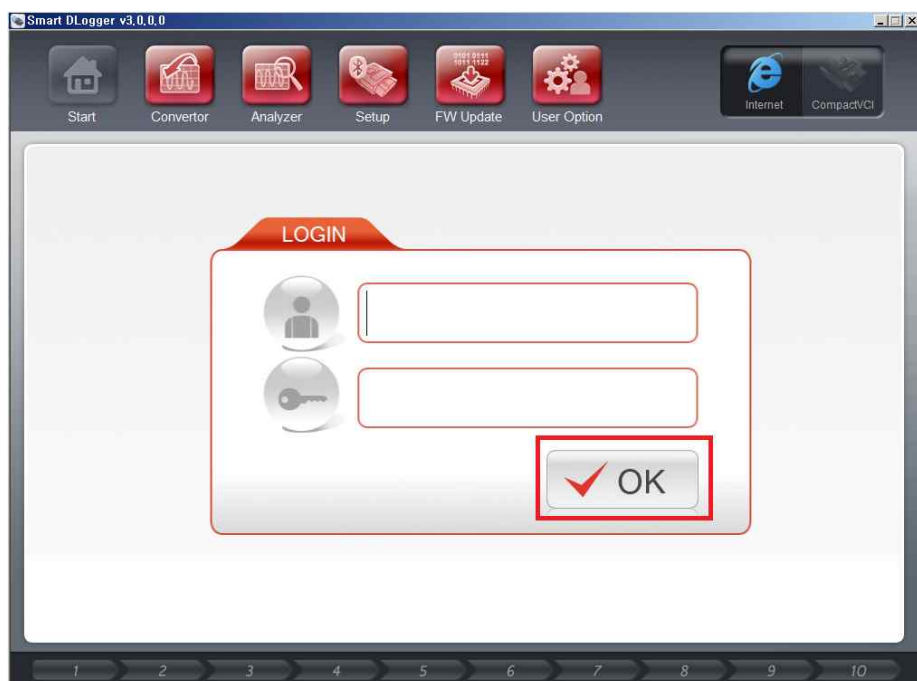


Fig. 5-5 Generation of events – Manual setup : VCI-II

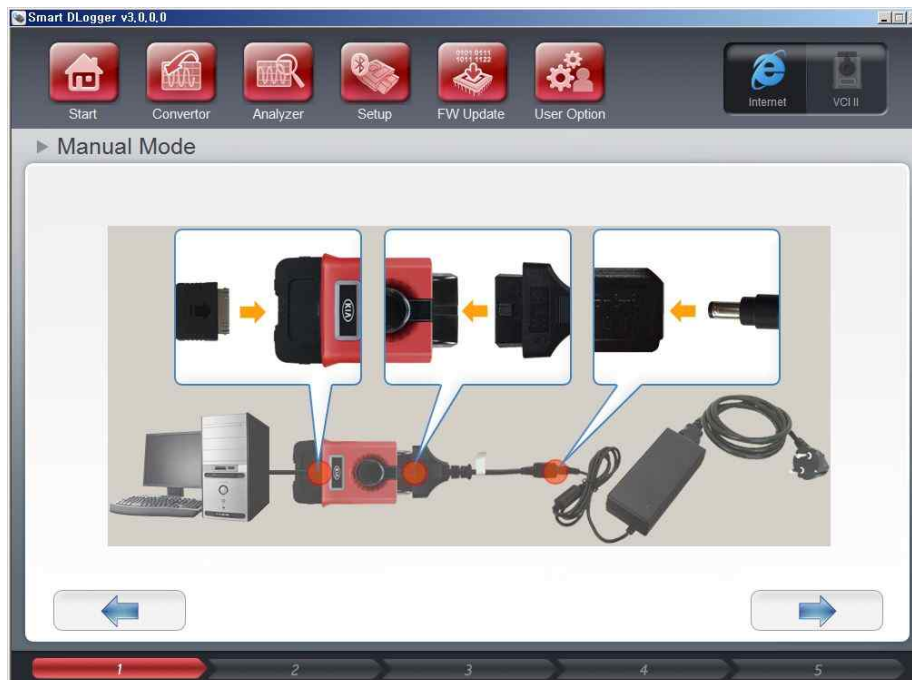
1) Login



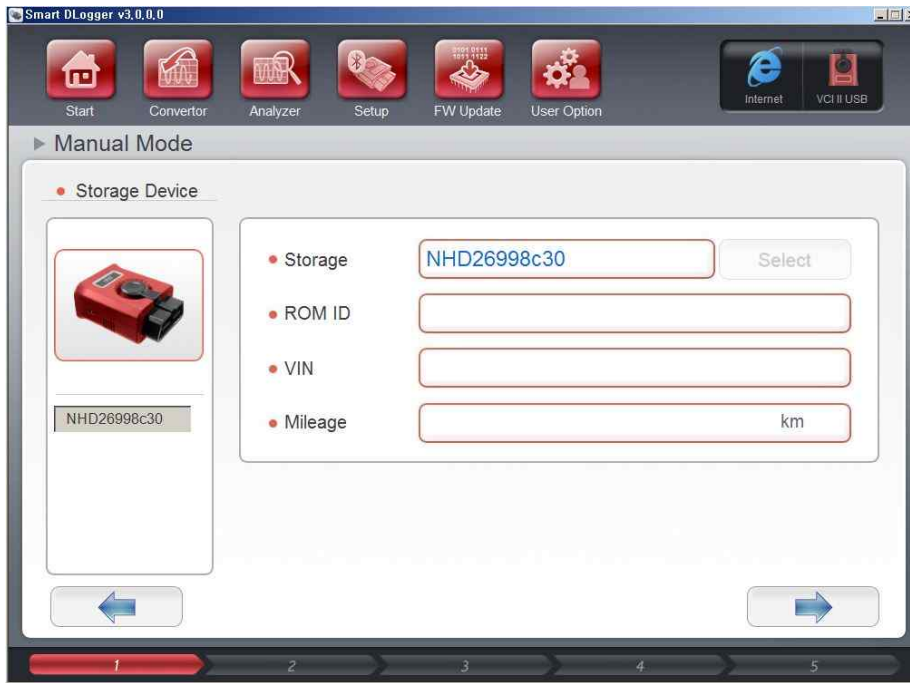
2) Select VCI-II



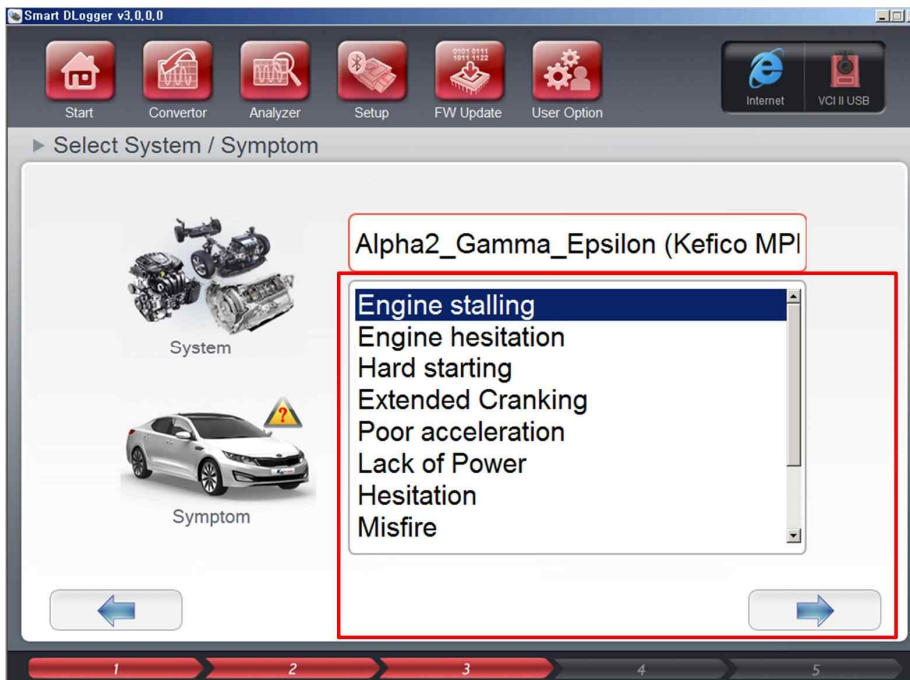
3) Power on the VCI-II, connect the VCI-II and PC via 30 pin to USB cable.



4) Select VCI-II connected to the PC, input ROM ID, VIN and Mileage



5) Select symptom





6) Generated event files.



7) Completion of generation of events

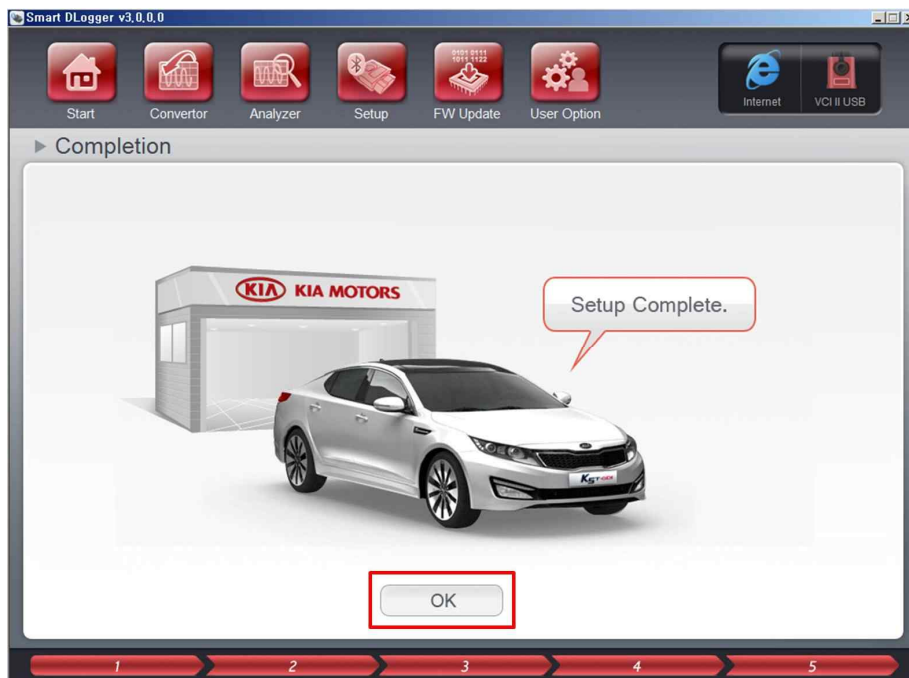
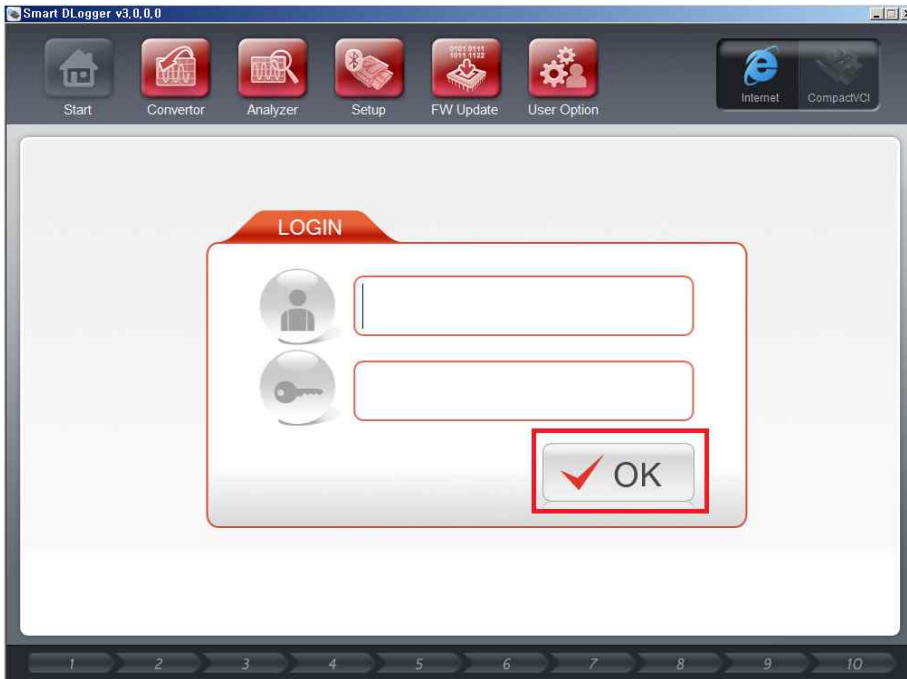


Fig. 5-6 Generation of events – Manual setup : CVCI-II

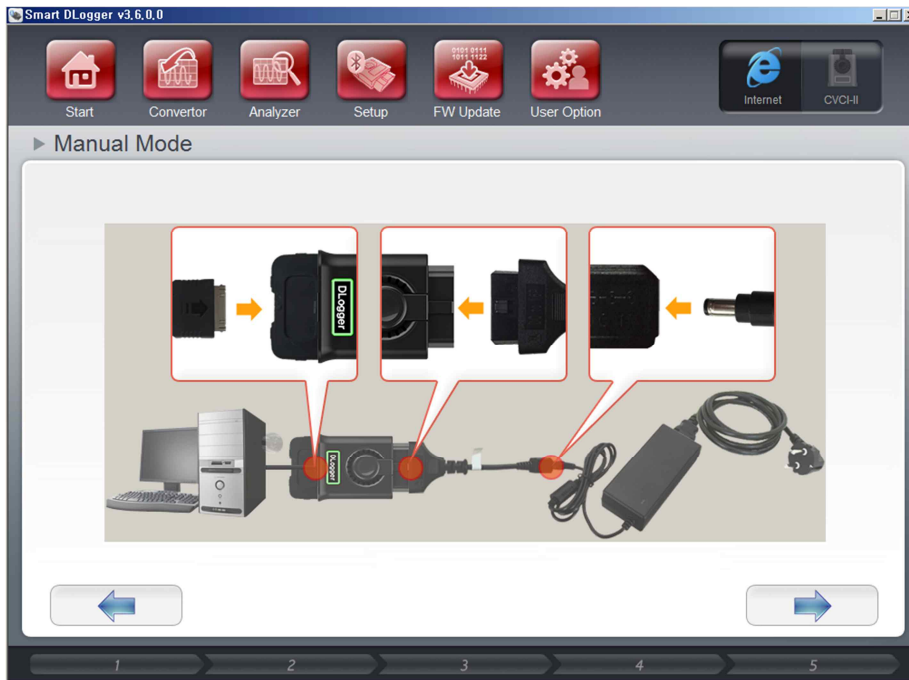
1) Login



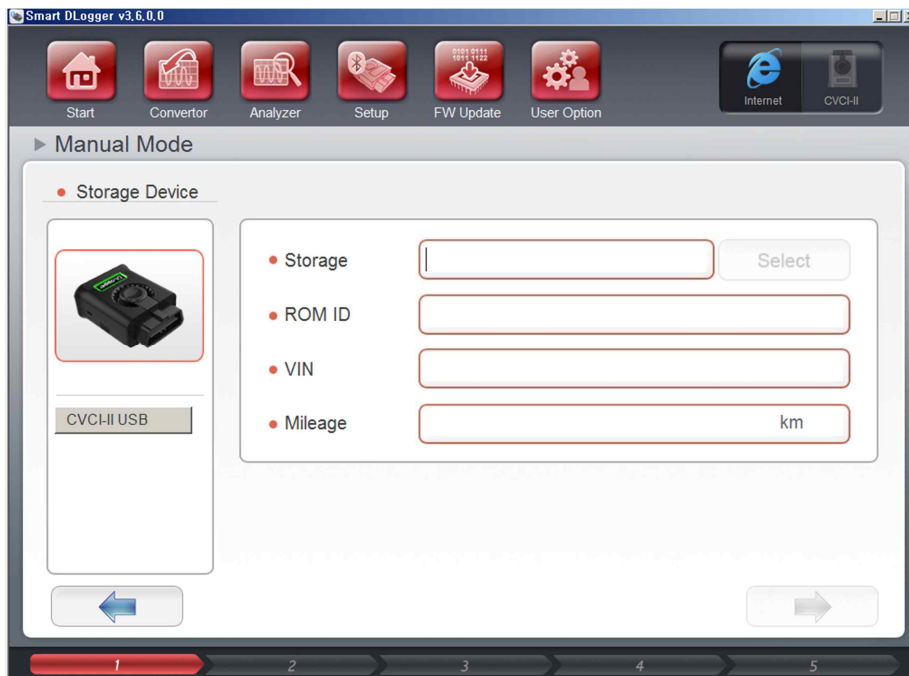
2) Select CVCI-II



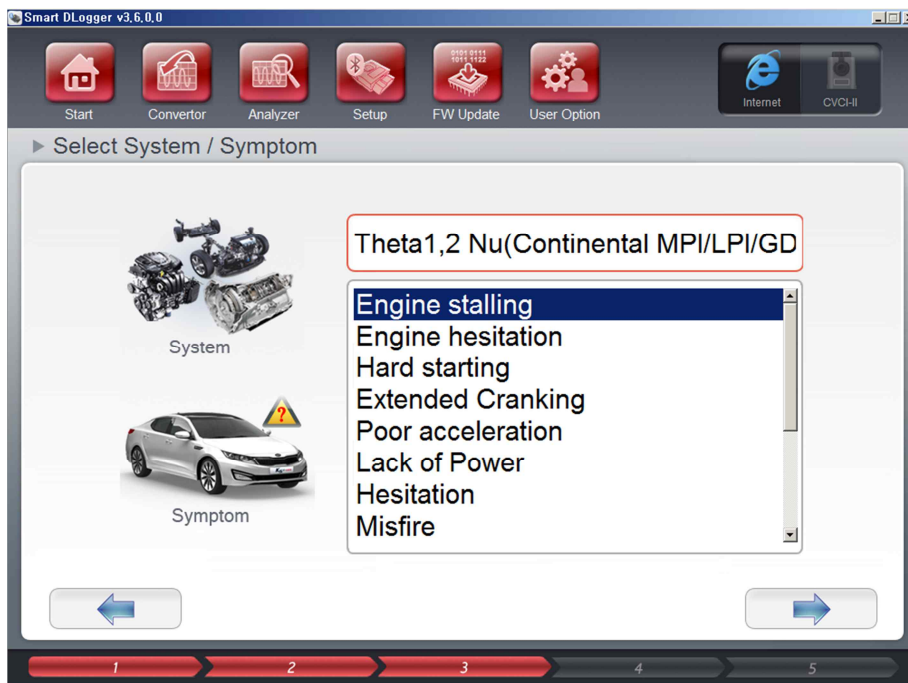
3) Power on the CVCI-II, connect the CVCI-II and PC via 30 pin to USB cable.



4) Select CVCI-II connected to the PC, input ROM ID, VIN and Mileage



5) Select symptom



6) Generated event files.



## 7) Completion of generation of events

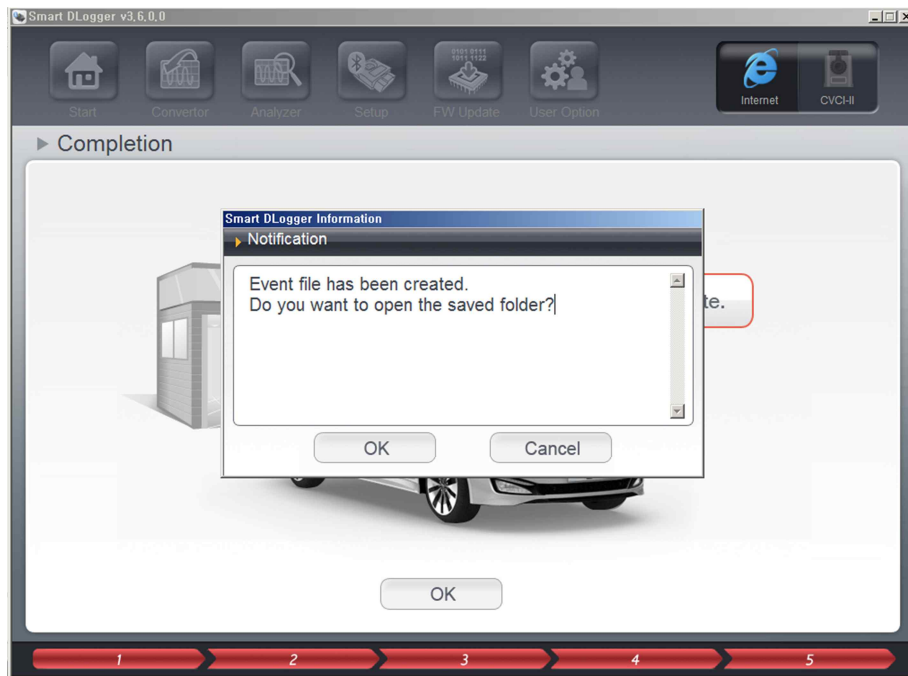


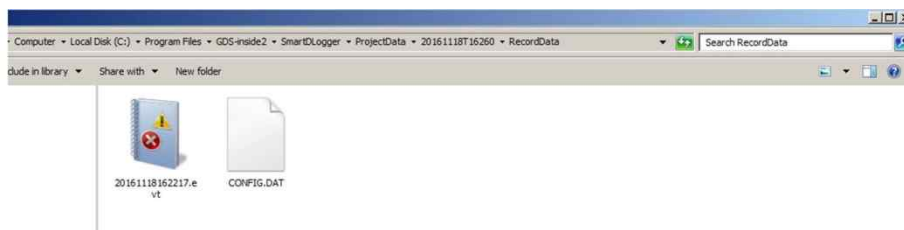
Fig. 5-7 When using the received events files : CVCI

1) Copy event file and config.dat files to SD card, then insert SD card into CVCI

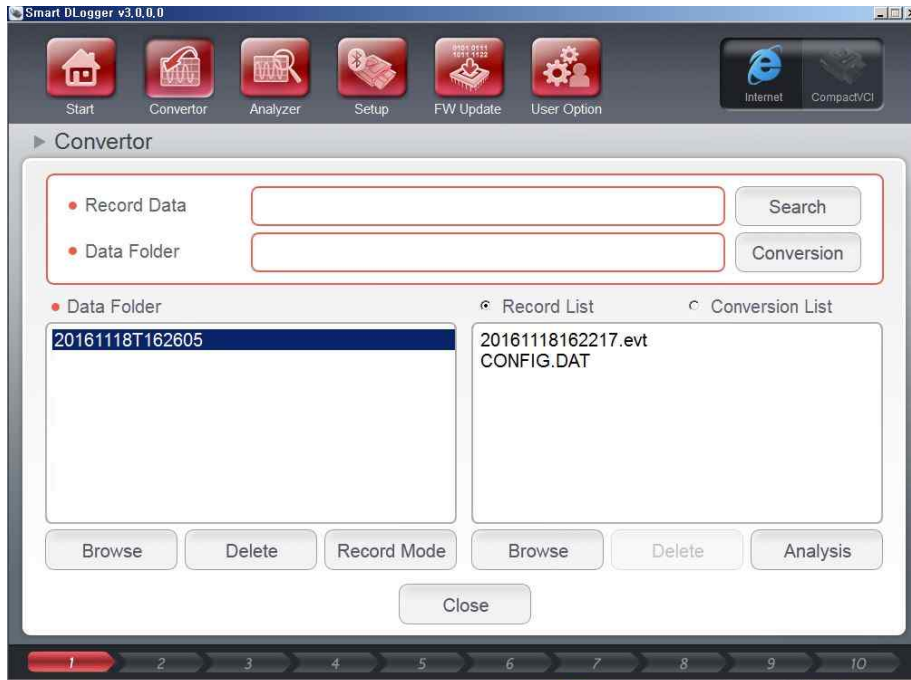


Fig. 5-8 When using the received events file : VCI-II

1) Create a new folder (ex. 20161118T16260) and sub folder (RecordData) in the folder path (default : C:\Program Files\WGDS-inside2\SmartDLogger\ProjectData) where the convertor data is located, then copy the event file and config.dat files.



- 2) From the Data Folder in the Convertor menu, select the folder where the event file and config.dat file is located then click Record Mode



- 3) Select VCI-II



4) Power on the VCI-II, connect the VCI-II and PC via 30 pin to USB cable.



5) Send event file and config.dat file to VCI-II.

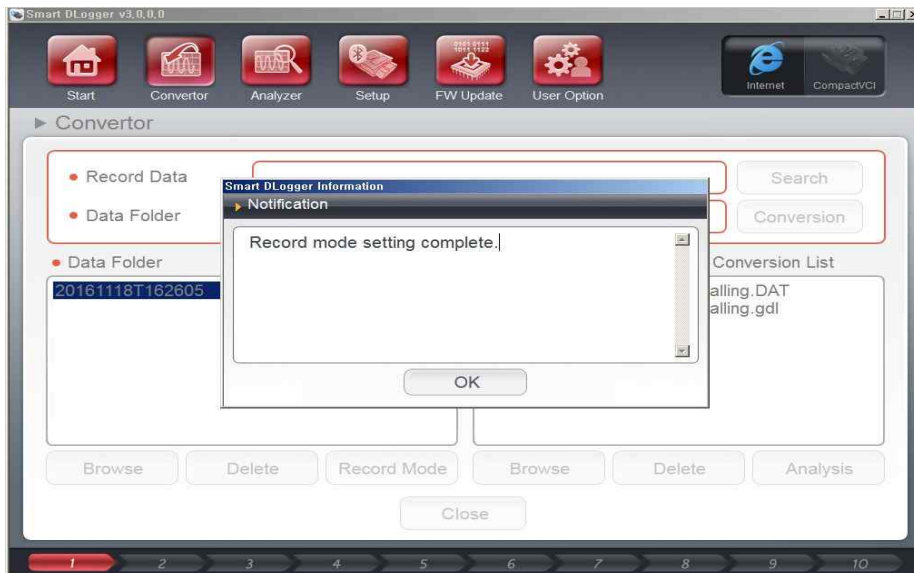
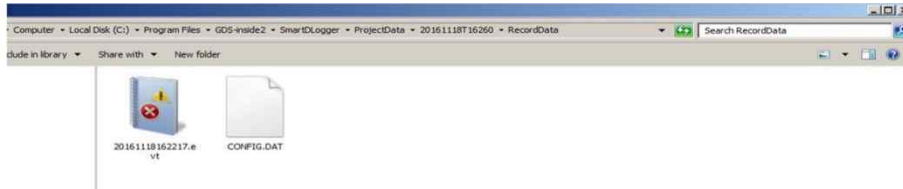
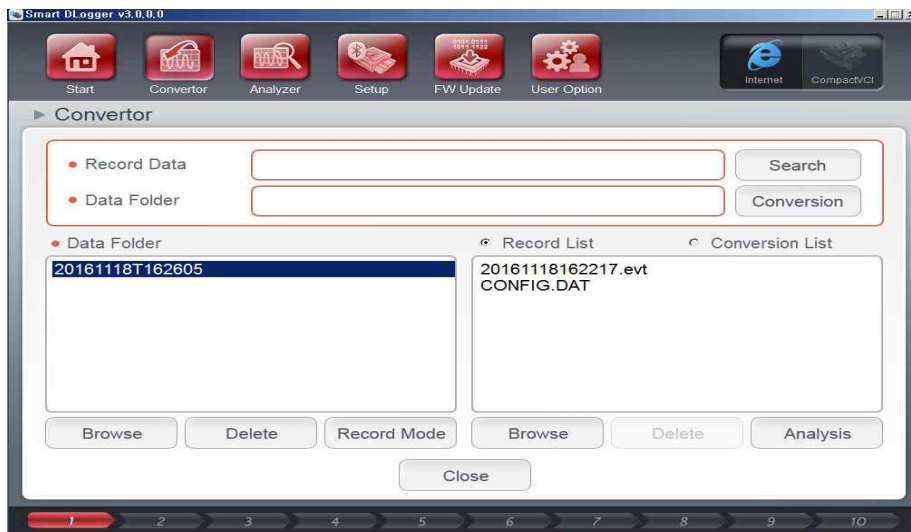


Fig. 5-9 When using the received events file : CVCI-II

- 1) Create a new folder (ex. 20161118T16260) and sub folder (RecordData) in the folder path (default : C:\Program Files\WGDS-inside2\SmartDLogger\ProjectData) where the convertor data is located, then copy the event file and config.dat files.



- 2) From the Data Folder in the Convertor menu, select the folder where the event file and config.dat file is located then click Record Mode

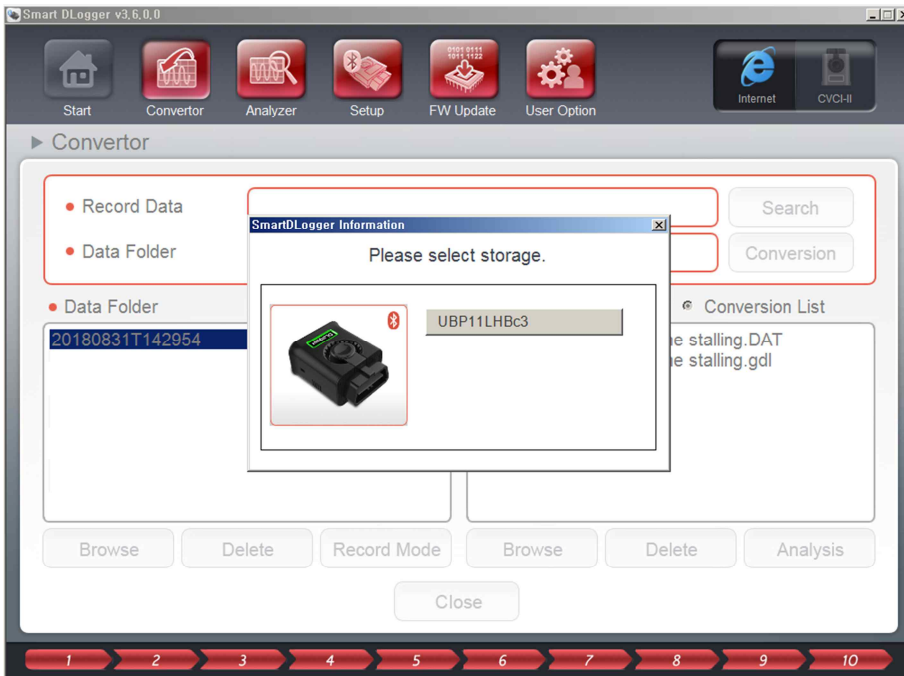


- 3) Select CVCI-II

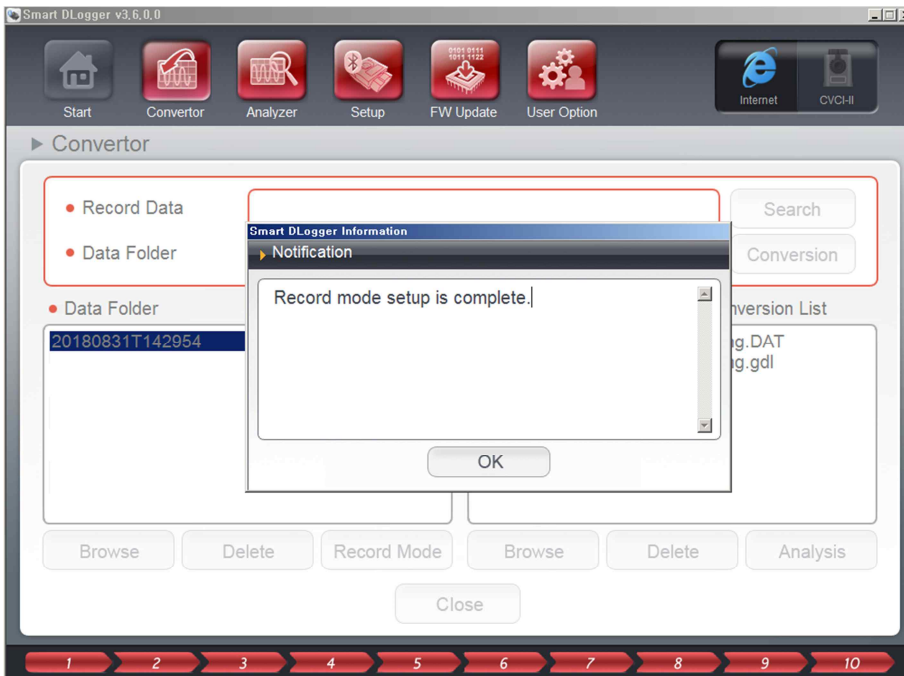




4) Power on the CVCI-II.



5) Send event file and config.dat file to CVCI-II.



---

### 5.3 Conversion of recording files

---

When data is recorded, a recording file is stored in the SD card of Compact VCI after raw formatting (with extension of rem). (ex; 20130705–100755.rem)

As this data is raw communication format data, it should be converted into physical data so that common users may easily identify it. This function is conversion.

When you execute conversion, a gdl file for programming DLogger analysis and a dat file in INCA MDA format to be used by the R&D center are generated. The reason for generating the dat file is to help researchers to analyze the data easily when the data is sent to the R&D center.

#### 5.3.1 gdl file

---

It is an exclusive DLogger gdl file that may be analyzed using a DLogger Analysis program.

DLogger Viewer is also supported to analyze dat files.

(ex; 20130806–101227\_Lack of Power.gdl)

#### 5.3.2 dat file

---

It is exclusive MDA dat file to be analyzed by INCA MDA that is used in the R&D center.

(ex; 20130806–101227\_Lack of Power.DAT)

### 5.4 Analyzing recorded data

---

If a recording file is converted, you may analyze the data using a DLogger analyzer.

Detailed method to use the analyzer will be explained in detail in “6. DLogger Analyzer.”

## 6. DLogger analyzer

---

DLogger Analyzer Program is an offline tool to display and analyze the recorded measurement data. This program is run as an own program screen and is run in display mode or analysis mode.

However, online measurement is impossible in case of DLogger Analyzer.

### 6.1 Explanation of functions

---

The DLogger analyzer helps you to perform the whole work from setting measurement variables to analysis of data smoothly in order to analyze the symptom and cause of recorded data.

The functions in the main menu and toolbar of the DLogger analyzer are as described below.

Fig. 6-1 Main screen of DLogger analyzer

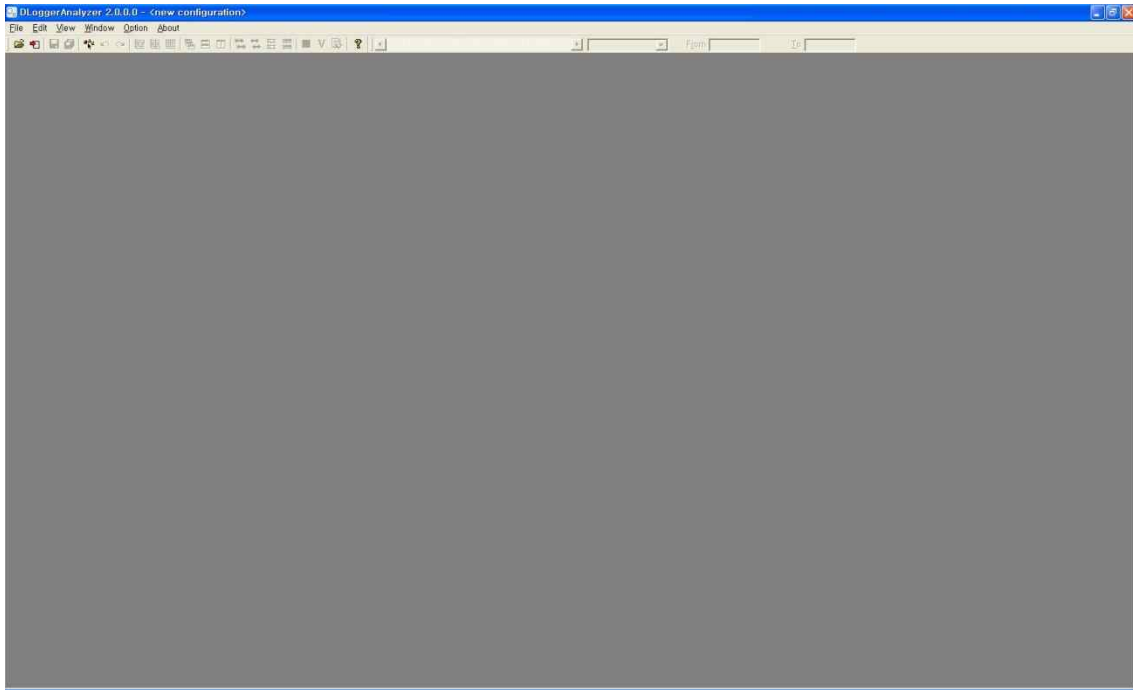
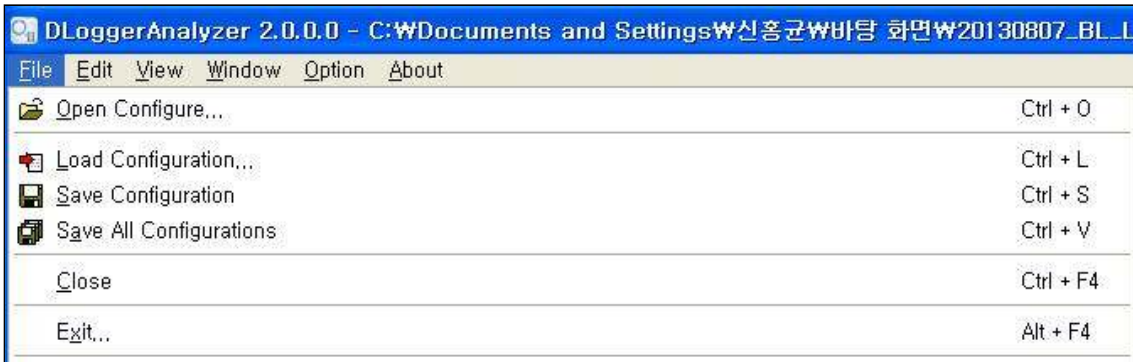


Fig. 6-2 Main menu of DLogger analyzer – File menu



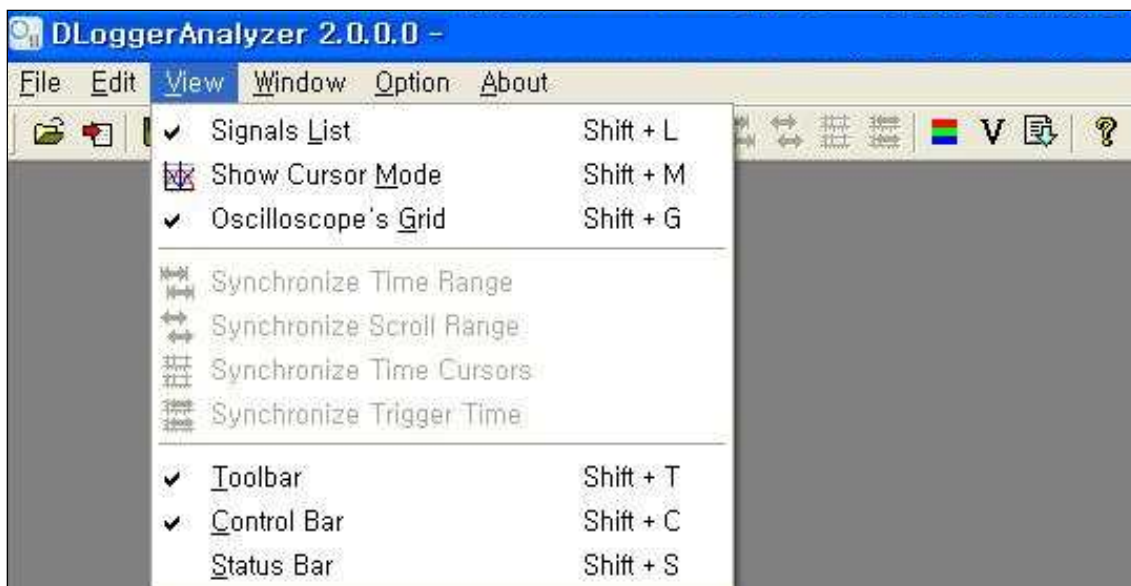
- 1) Open Configure – It calls a file.
- 2) Load Configuration – It calls an environment file.
- 3) Save Configuration – It stores currently opened file as an environment file.
- 4) Save All Configuration – It stores all opened file as an environment file.
- 5) Close (It appears only when there is a called file.) – It closes opened files.
- 6) Exit – It terminates the program.

Fig. 6-3 Main menu of DLogger analyzer – Edit menu



- 1) Measured Variables – It calls the dialogue to select variables.
- 2) Undo Zoom (It appears only when there is a called file.) – Return
- 3) Redo Zoom (It appears only when there is a called file.) – Doing again

Fig. 6-4 Main menu of DLogger analyzer – View menu



- 1) Signals List (It appears only when there is a called file.) – It selects whether to activate the list of variables.
- 2) Show Cursor Mode (It appears only when there is a called file.) – It selects whether to activate cursor mode.
- 3) Oscilloscope's Grid (It appears only when there is a called file.) – It selects whether to activate graph grid mode.
- 4) Toolbar – It selects whether to activate the toolbar.
- 5) Control Bar – It selects whether to activate control bar.
- 6) Status Bar – It selects whether to activate status bar.

Fig. 6-5 Main menu of DLogger analyzer – Window menu



- 1) Cascade – It displays information in the arrangement of stairway type window.
- 2) Tile Horizontally – It displays information in the arrangement of widthwise checker type window.
- 3) Tile Vertically – It displays information in the arrangement of lengthwise checker type window.
- 4) Minimize All – It minimizes all.
- 5) Close Active Window – It closes active window.
- 6) Close All Window – It closes all the windows.
- 7) Oscilloscope[n] / Table[n] (It appears only when there is a called file.) – Opened window is selected.

Fig. 6-6 Main menu of DLogger analyzer – Option menu



- 1) Change Chart Background Color – It changes the background color of the graph.
- 2) Change Language – It changes the language.
- 3) Save Current Language – It stores currently selected options of the language.

Fig. 6-7 Main menu of DLogger analyzer – About menu



- 1) About Me – It displays the information on the analyzer.

Fig. 6-8 Main toolbar of DLogger analyzer



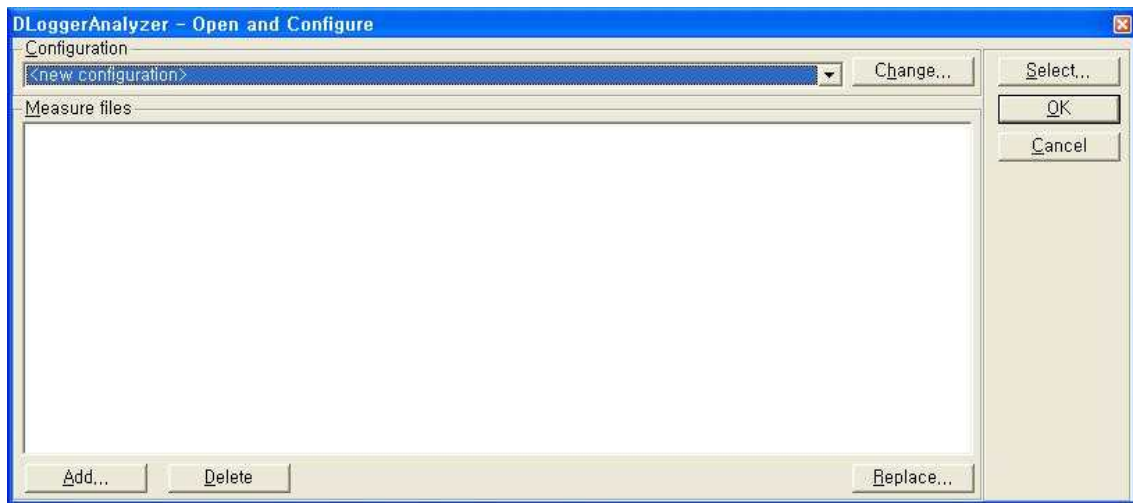
- 1) Open file
- 2) Open environment file
- 3) Save
- 4) Save all
- 5) Select variables
- 6) Undo
- 7) Redo
- 8) Activate variables list mode
- 9) Activate cursor mode
- 10) Activate chart grid mode
- 11) Stairway type window arrangement
- 12) Widthwise checker type window arrangement
- 13) Lengthwise checker type window arrangement
- 14) To meet time range
- 15) To meet scroll range
- 16) To meet time cursor mode
- 17) To meet trigger time mode
- 18) Change chart background color
- 19) Change language
- 20) Save current language state
- 21) Help

Fig. 6–9 Control bar of DLogger analyzer



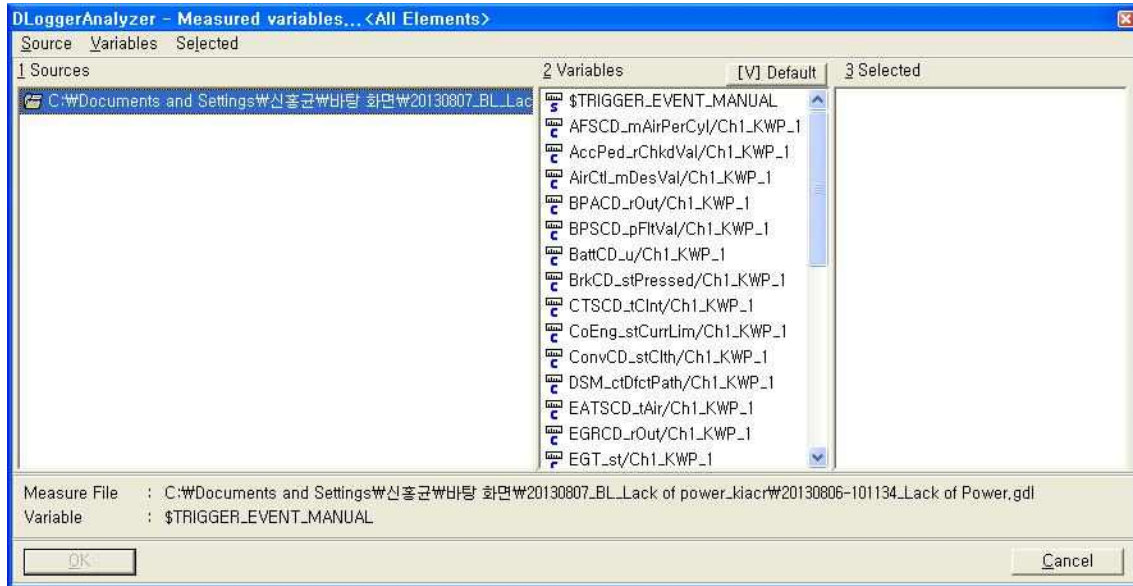
- 1) Scroll area
- 2) Select window
- 3) From – starting time
- 4) To – Ending time

Fig. 6–10 Popup window of DLogger Analyzer – Open and Configure



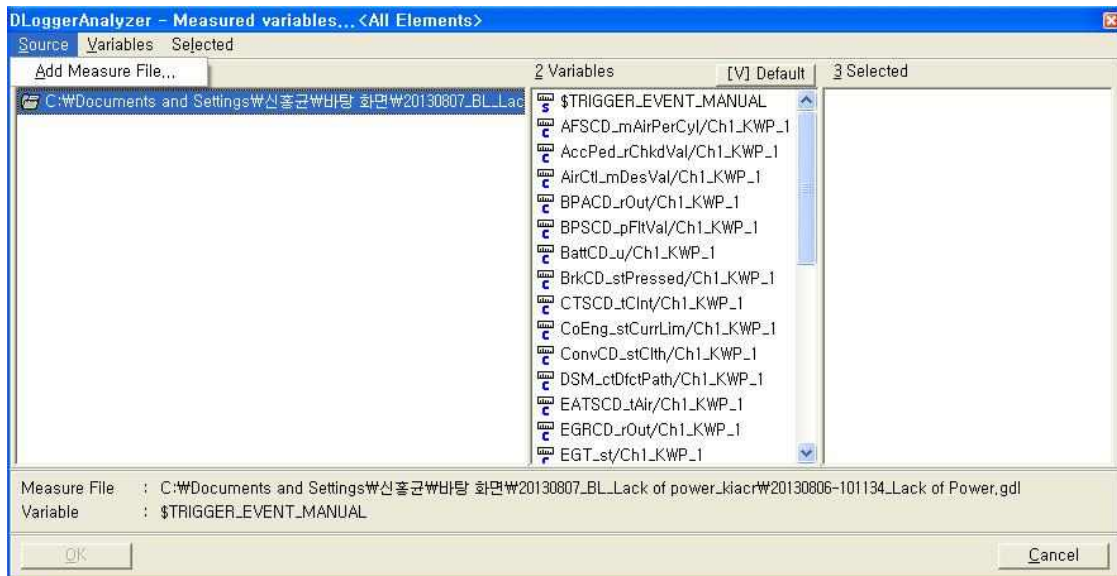
- 1) Change button – It calls an existing environment file.
- 2) Add button – It calls a file.
- 3) Delete button – It deletes a called file.
- 4) Replace button – It changes a called file.
- 5) Select button – It selects a file.
- 6) OK button – It confirms a selected file.
- 7) Cancel button – It cancels.

Fig. 6-11 Popup window of DLogger Analyzer – Measured Variables



- 1) Source – A called file
- 2) Variables – List of the variables of a called file
- 3) Selected – List of selected variables
- 4) [V] Default button – It changes the language.
- 5) OK button – It proceeds the next step.
- 6) Cancel button – It cancels.

Fig. 6-12 Popup window of DLogger Analyzer – Main Menu of Measured Variables – Source

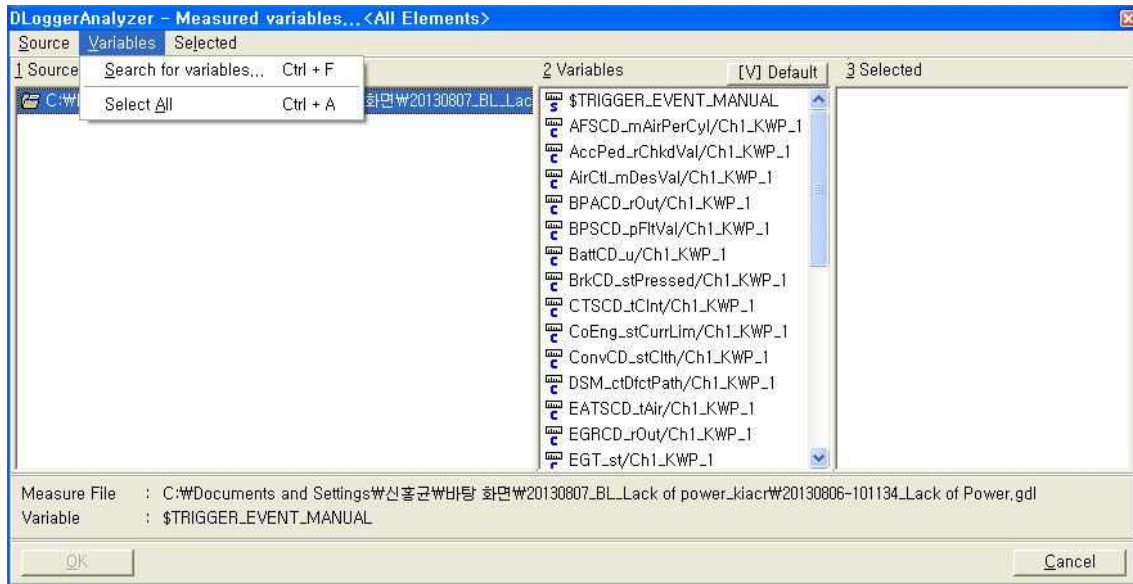


- 1) Add Measure File – It adds a new file.

Fig. 6-13 Popup windows of DLogger Analyzer – Main Menu of Measured Variables –

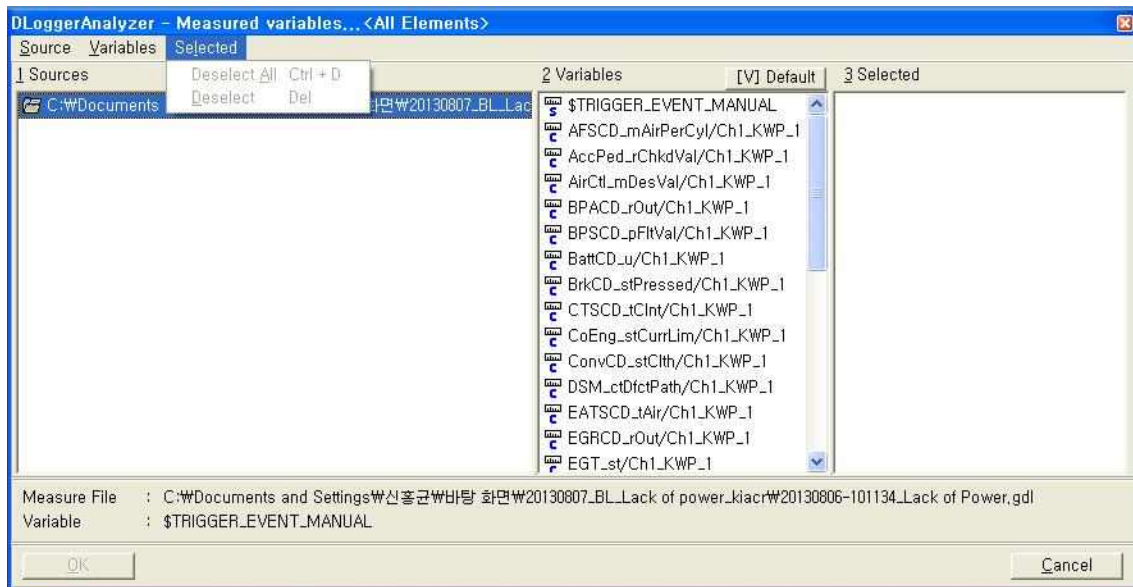


## Variables



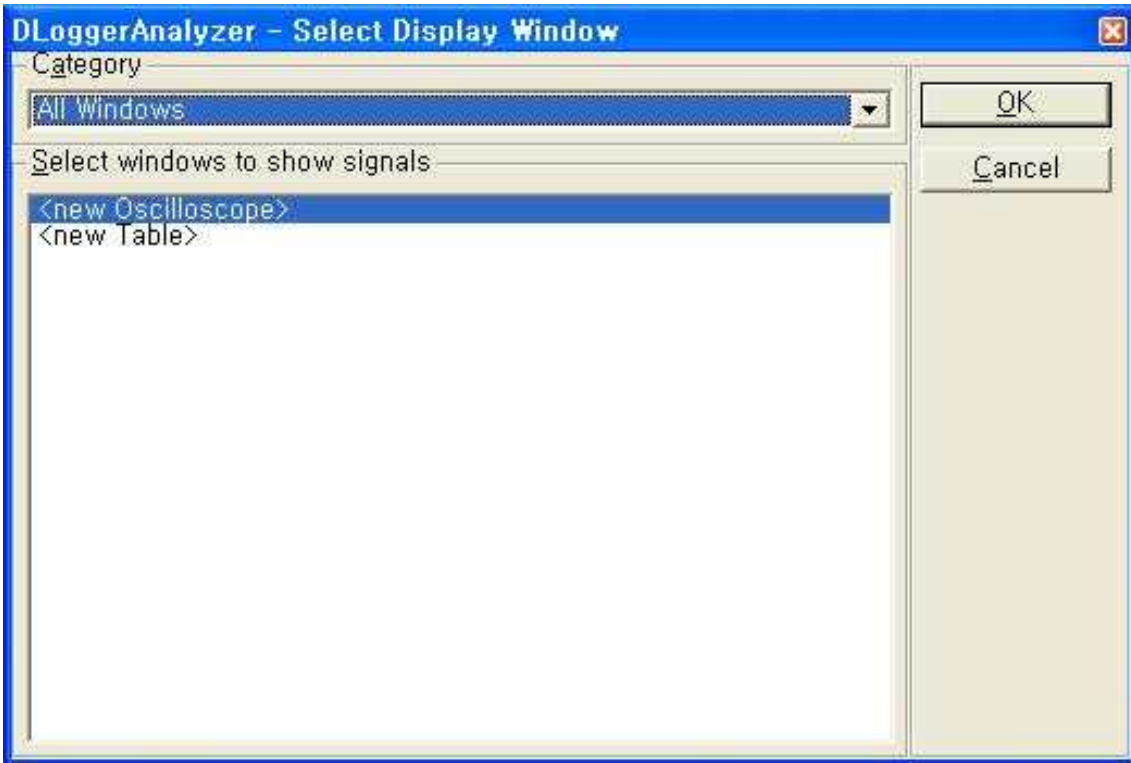
- 1) Search for variables – It searches variables.
- 2) Select All – It selects all.

Fig. 6–14 Popup window of DLogger Analyzer – Main Menu of Measured Variables – Selected



- 1) Deselect All – It releases all the selected variables.
- 2) Deselect – It releases a selected variable.

Fig. 6–15 Popup window of DLogger Analyzer – Select Display Window



- 1) OK button – It proceeds the next step.
- 2) Cancel button – It cancels.

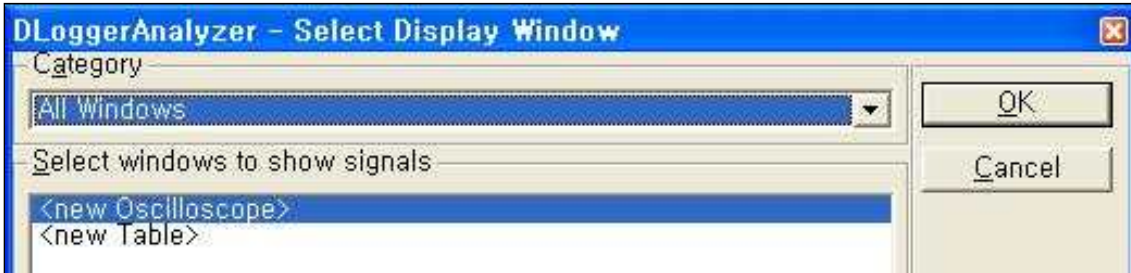
Fig. 6-16 Popup window of DLogger Analyzer – Select Display Window – Category



- 1) All Windows – It displays all in window form.

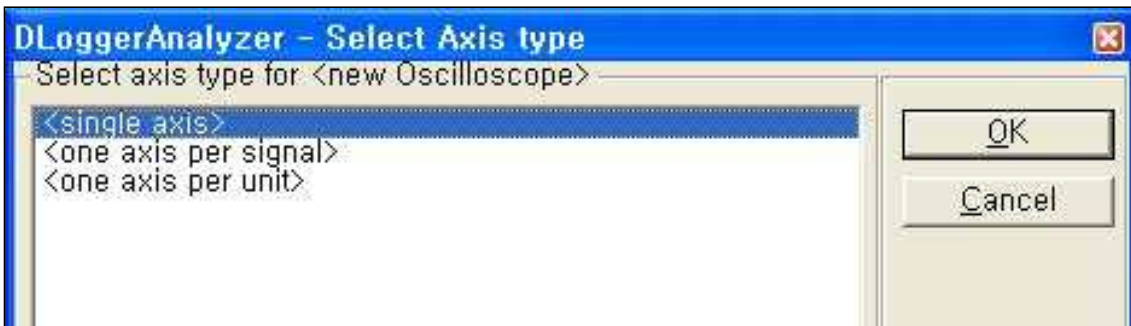
- 
- 2) All Oscilloscopes – It displays all in chart form.
  - 3) All Table – It displays all in table form.

Fig. 6-17 Popup window of DLogger Analyzer – Select Display Window – Select windows to show signals



- 1) <new Oscilloscope> – It displays the information in chart form.
- 2) <new Table> – It displays information in table form.

Fig. 6-18 Popup window of DLogger Analyzer – Select Axis type



- 1) <signal axis> – It displays the information in the variable axis.
- 2) <one axis per signal> – It displays the information in an axis by variable.
- 3) <one axis per unit> – It displays the information in an axis by unit.
- 4) OK button – It proceeds the next step.
- 5) Cancel button – It cancels.

Fig. 6-19 Oscilloscope window of DLogger analyzer

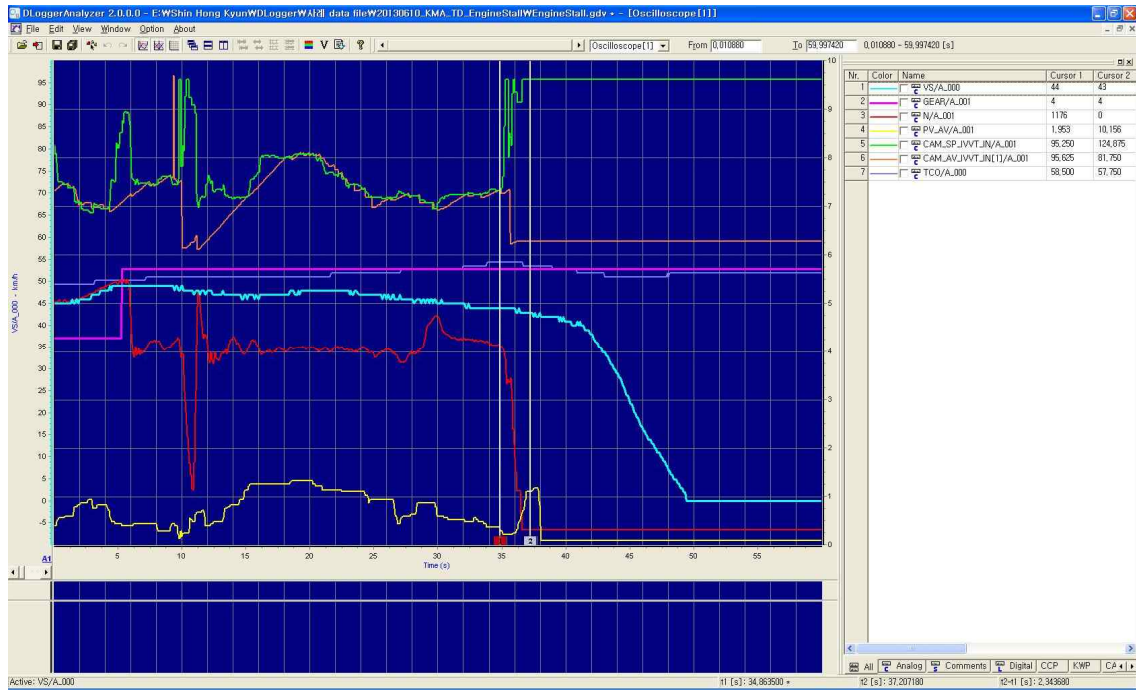


Fig. 6-20 Oscilloscope of DLogger analyzer – Signal List of Oscilloscope

Nr.	Color	Name	Cursor 1	Cursor 2	Diff.	Units	Description	Channel	Protocol	Per-Div.	Base	Signal Description
1		VS/A_000	48	41	-7	km/h			CCP	11,000000	-10,000000	
2		GEAR/A_001	4	4	0	-			CCP	0,700000	0,000000	
3		N/A_001	1166	0	-1166	rpm			CCP	310,000000	-100,000000	
4		PV_AV/A_001	12,500	0,000	-12,500	%			CCP	10,100000	-1,000000	
5		CAM_AV_JVVT_IN[1]/A_001	104,625	81,750	-22,875	?CRK			CCP	13,000000	0,000000	
6		CAM_SP_JVVT_IN[1]/A_001	105,000	124,875	19,875	?CRK			CCP	13,000000	0,000000	
7		TCO/A_000	55,500	57,000	1,500	?C			CCP	10,000000	0,000000	
8		ERR_DTC[0]/A_000	0	0	0	-			CCP	0,200000	-1,000000	
9		ERR_DTC[1]/A_000	0	0	0	-			CCP	0,200000	-1,000000	
10		ER_CYL[0]/A_001	403,881	0,000	-403,881	?s			CCP	3992,70545E	-2618,5751E	
11		ER_CYL[1]/A_001	303,745	0,000	-303,745	?s			CCP	1827,378317	-1822,2093E	
12		ER_CYL[2]/A_001	569,105	0,000	-569,105	?s			CCP	2220,401844	-1858,0437E	
13		ER_CYL[3]/A_001	199,080	0,000	-199,080	?s			CCP	2527,062797	-1662,9337E	
14		LOAD_MIS/A_000	72,604	0,000	-72,604	%			CCP	8,042877	-3,655853	
15		TL1_HOM[0]/A_000	8,596	8,544	-0,052	ms			CCP	1,207800	1,479000	
16		TPS_AV_1/A_000	7,790	5,223	-2,568	?TPS			CCP	0,936350	1,208275	
17		TPS_AV_2/A_000	7,892	5,325	-2,568	?TPS			CCP	0,925117	1,315499	
18		VB/A_000	14,320	12,492	-1,828	V			CCP	0,335156	11,832031	
19		VLS_DOWN[1]/A_000	0,801	0,767	-0,034	V			CCP	0,052637	0,400879	
20		VLS_UP[1]/A_001	1,973	2,231	0,259	V			CCP	0,241699	1,164551	

- 1) Nr. – Order
- 2) Color – Graph color
- 3) Name – Name
- 4) Cursor 1 – Cursor 1
- 5) Cursor 2 – Cursor 2

- 6) Diff – Value of (Data of Cursor 2 – Data of Cursor 1)
- 7) Unit – Unit
- 8) Description – Description
- 9) Channel – Channel
- 10) Protocol – Protocol
- 11) Pev–Div. – Mean value
- 12) Base – Deviation
- 13) Signal Description – Description of a variable
- 14) All – All variables
- 15) Analog – Analogue variables
- 16) Comments – Comment variables
- 17) Digital – Digital variables
- 18) CCP – CCP variables
- 19) KWP – KWP variables
- 20) CAN – CAN variables
- 21) XCP – XCP variables
- 22) A1, A2, ~ An – Each selected variable

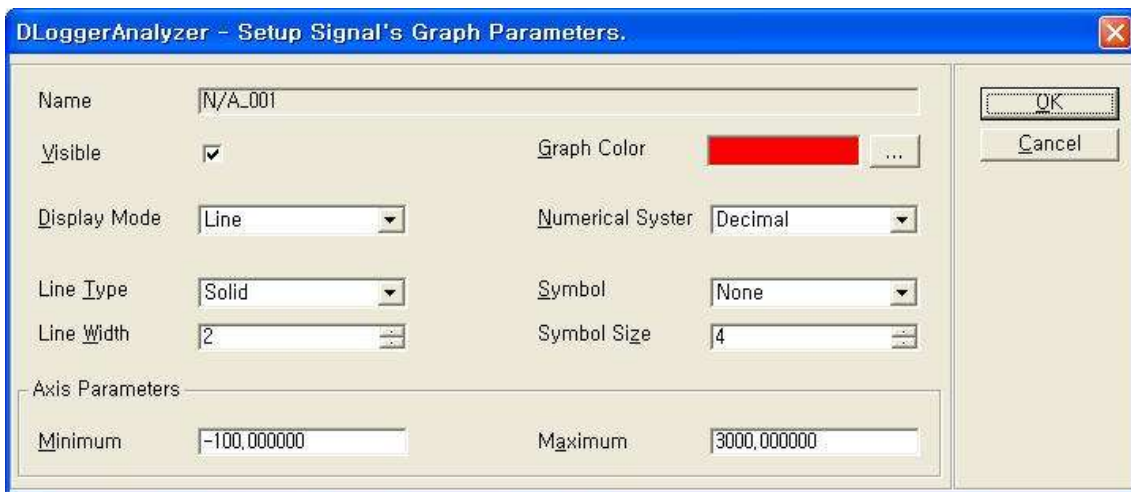
Fig. 6–21 Oscilloscope of DLogger analyzer – Signal List of Oscilloscope – Additional Functions

Nr.	Color	Name	Cursor 1	Cursor 2	Diff.	Units	Description	Channel	Protocol	Per-Div.	Base	Signal Description
1		VS/A_000	48	41	-7	km/h			CCP	11,000000	-10,000000	
2		GEAR/A_001	4	4	0	-			CCP	0,700000	0,000000	
3		N/A_001	1166	0	-1166	rpm			CCP	310,000000	-100,000000	
4		PV_AV/A_001							CCP	10,100000	-1,000000	
5		CAM_AV_IVVT							CCP	13,000000	0,000000	
6		CAM_SP_IVVT							CCP	13,000000	0,000000	
7		TCO/A_000							CCP	10,000000	0,000000	
8		ERR_DTC[0]/A_000							CCP	0,200000	-1,000000	
9		ERR_DTC[1]/A_000							CCP	0,200000	-1,000000	
10		ER_CYL[0]/A_000							CCP	3992,70545E	-2618,5751E	
11		ER_CYL[1]/A_000							CCP	1827,378317	-1822,2093E	
12		ER_CYL[2]/A_000							CCP	2220,401844	-1858,0437E	
13		ER_CYL[3]/A_000							CCP	2527,062797	-1662,9337E	
14		LOAD_MIS/A_000							CCP	8,042877	-3,655853	
15		TL1_HOM[0]/A_000	8,596	8,544	-0,052	ms			CCP	1,207800	1,479000	
16		TPS_AV_1/A_000	7,790	5,223	-2,568	?TPS			CCP	0,936350	1,208275	
17		TPS_AV_2/A_000	7,892	5,325	-2,568	?TPS			CCP	0,925117	1,315499	
18		VB/A_000	14,320	12,492	-1,828	V			CCP	0,335156	11,832031	
19		VLS_DOWN[1]/A_000	0,801	0,767	-0,034	V			CCP	0,052637	0,400879	
20		VLS_UP[1]/A_001	1,973	2,231	0,259	V			CCP	0,241699	1,164551	

- 1) Signal Configuration – It edits the attributes of a selected variable.
- 2) Add variables – It adds a variable.
- 3) This signal scale – Scale of a selected variable

- 4) Default Scale – Default scale
- 5) Move selected variable to Axis – It moves selected variable to axis.
- 6) Remove – It deletes variables.
- 7) Remove selected variables – It deletes selected variables.
- 8) Select all variables – It deletes all the variables.
- 9) Deselected all variables – It releases all the selected variables.
- 10) Invisible of selected variables – It hides selected variables.
- 11) Visible of invisible variables – It displays hidden variables.
- 12) DLogger Versions and A2L information – Information on DLogger version and A2L

Fig. 6–22 Oscilloscope of DLogger analyzer – Signal Configuration



- 1) Name – Name of a variable
- 2) Visible – It activates a variable when checked.
- 3) Display Mode – Display mode (Line/Step/Step None Connect)
- 4) Line Type – Line type (Solid/Dash/Dot/Dash-Dot/Dash-Dot-Dot )
- 5) Line Width – Line thickness (0~8)
- 6) Graph Color – It selects graph color.
- 7) Numerical System – Antilogarithm (Decimal/Hexadecimal))
- 8) Symbol – Symbol (None/Square/Circle/Triangle/Down Triangle/Cross/Diagonal  
Cross/Star/Diamond/Left Triangle/Right Triangle/Hexagon)
- 9) Symbol Size – Symbol size (4~8)
- 10) Axis Parameters – Minimum – Minimum value of axis
- 11) Axis Parameters – Maximum – Maximum value of axis
- 12) OK button – It applies the setting.
- 13) Cancel – It cancels.

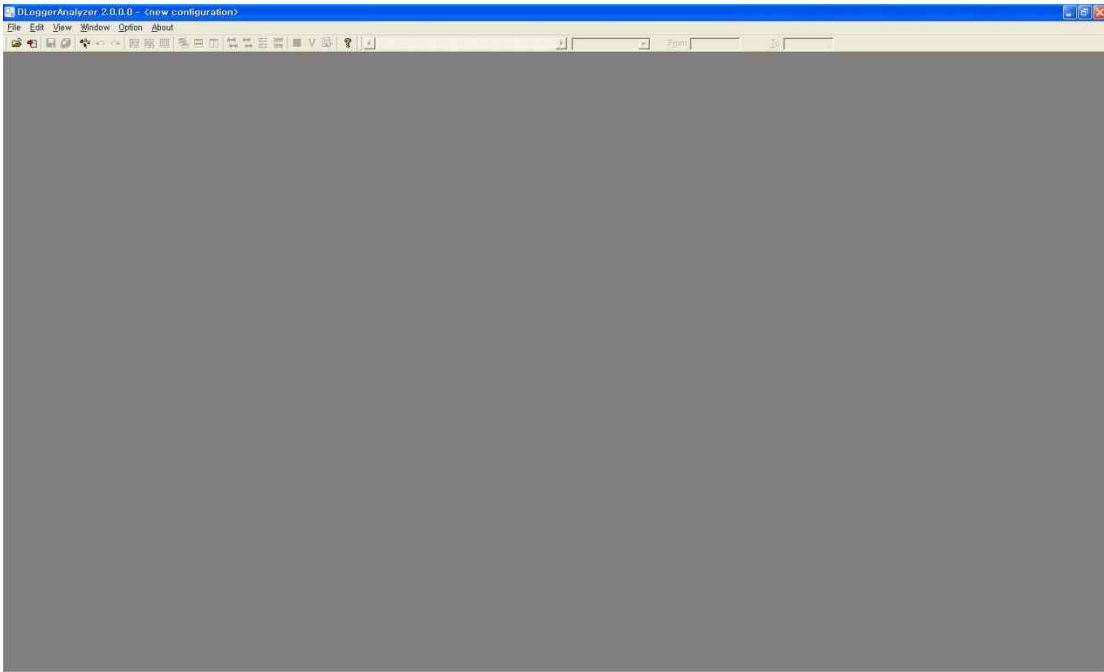
---

## 6.2 Method of analysis

---

This part introduces example to analyze data in relation to the method to analyze recorded data using the DLogger analyzer.

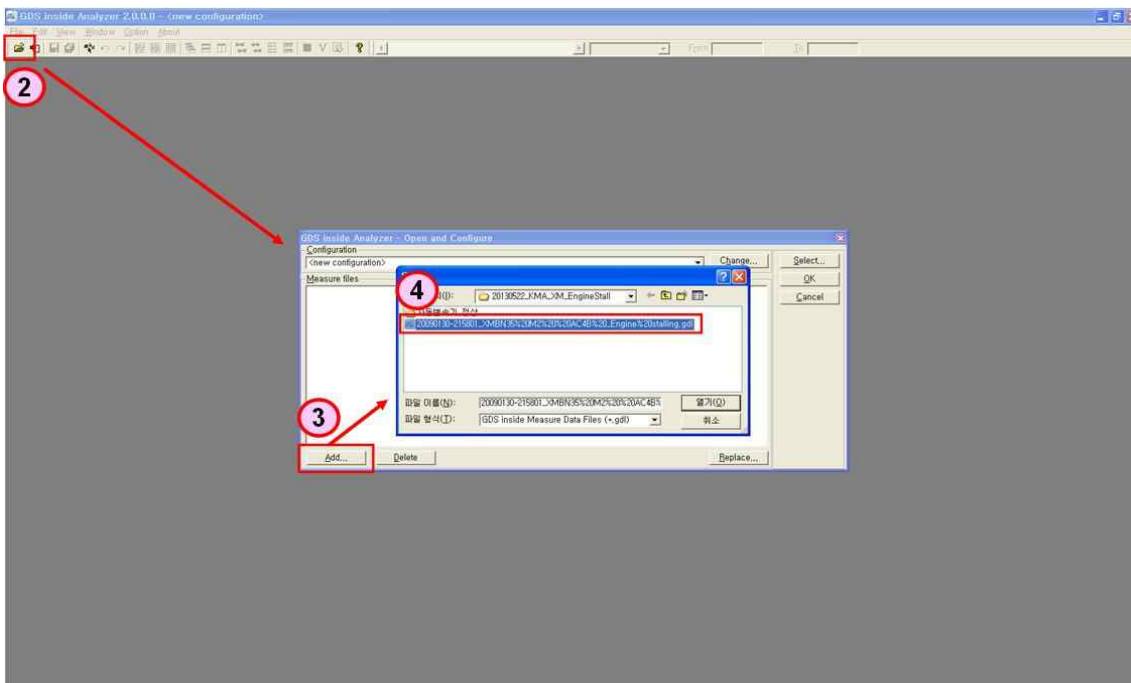
1) Open DLogger Analyzer Program.



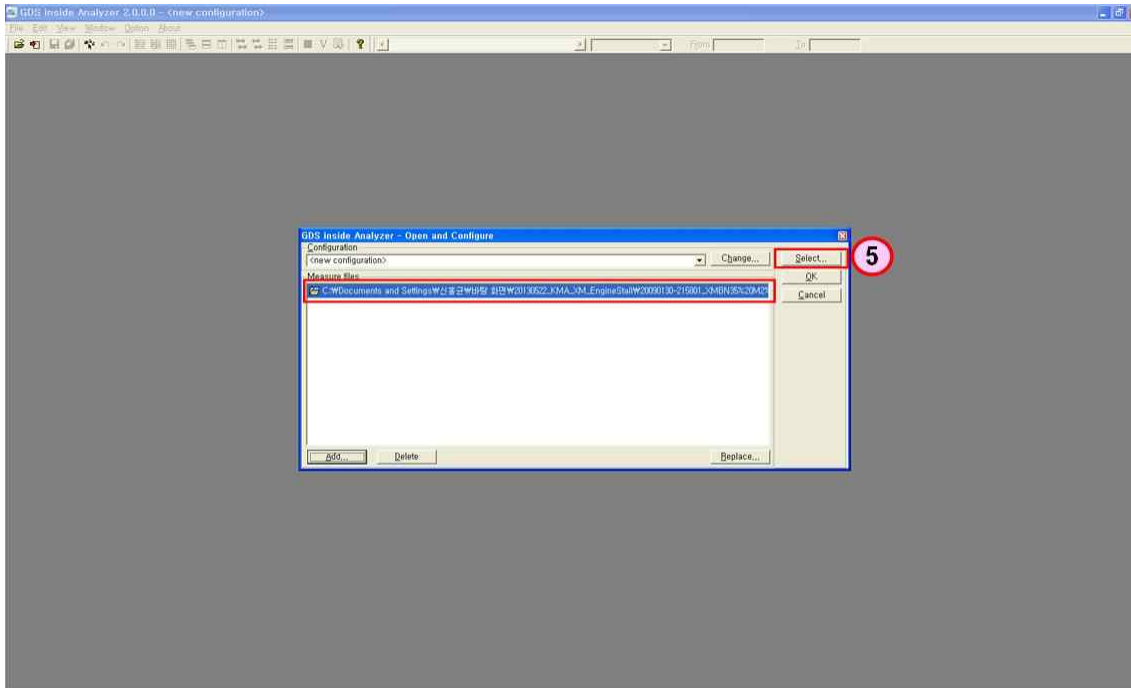
2) Click Open File.

3) Select Add in the screen of Open and Configure.

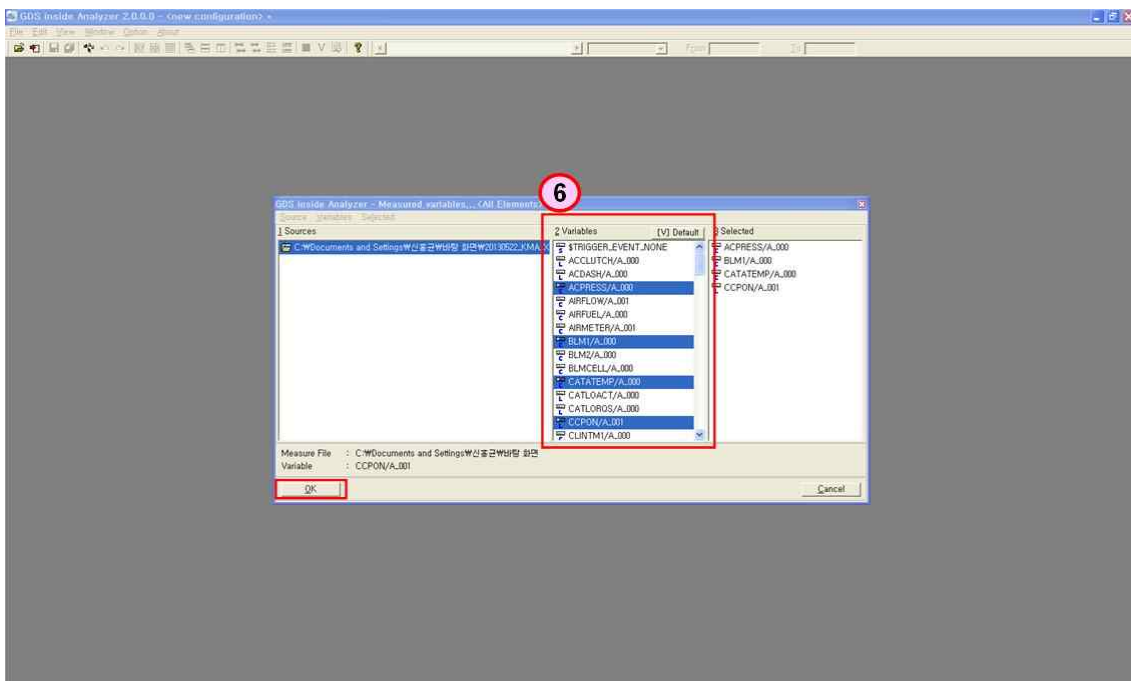
4) Select a recorded file and open it.



5) Click Select.



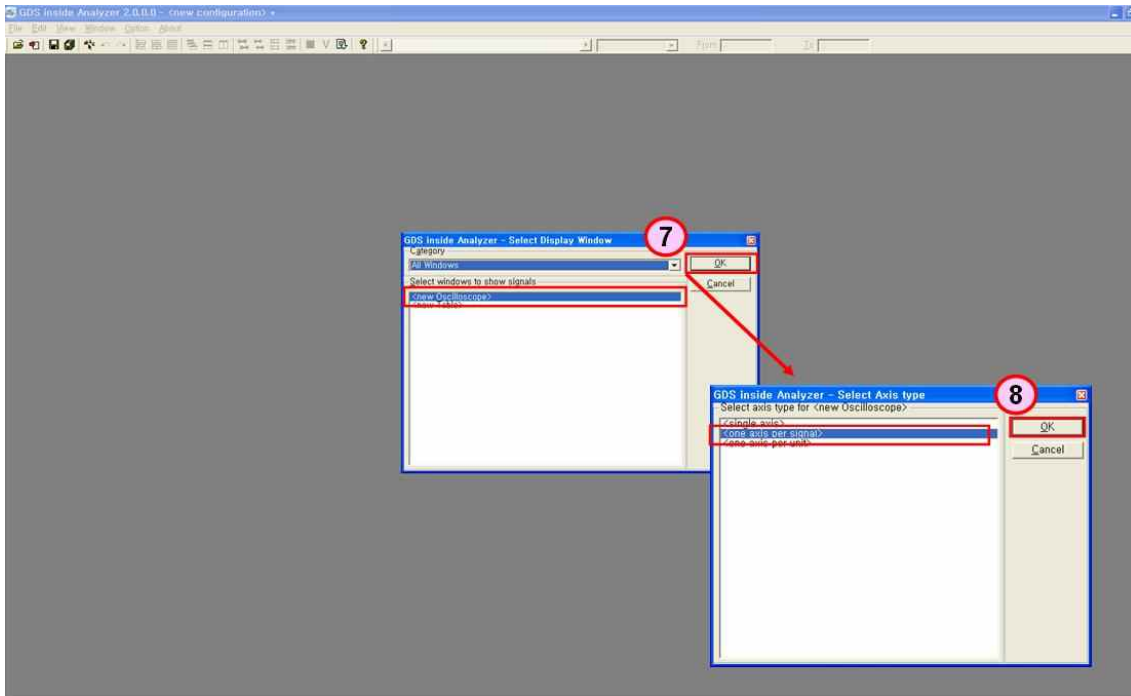
6) Select a variable in the screen of Variables.



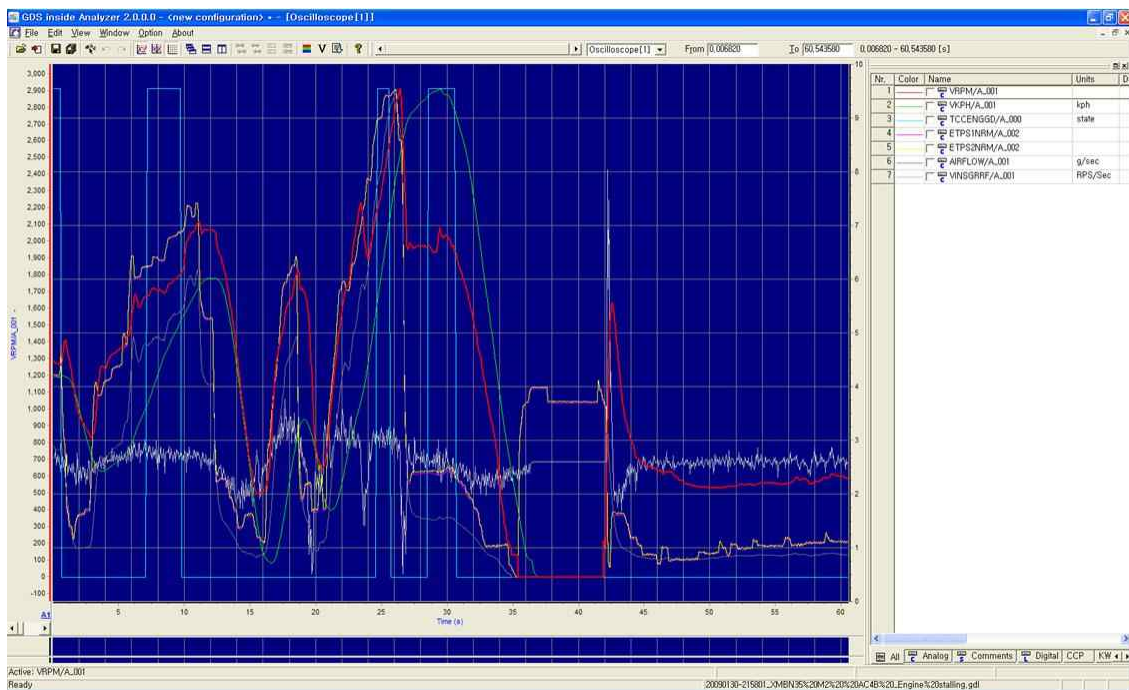


7) Select <New Oscilloscope> and click OK.

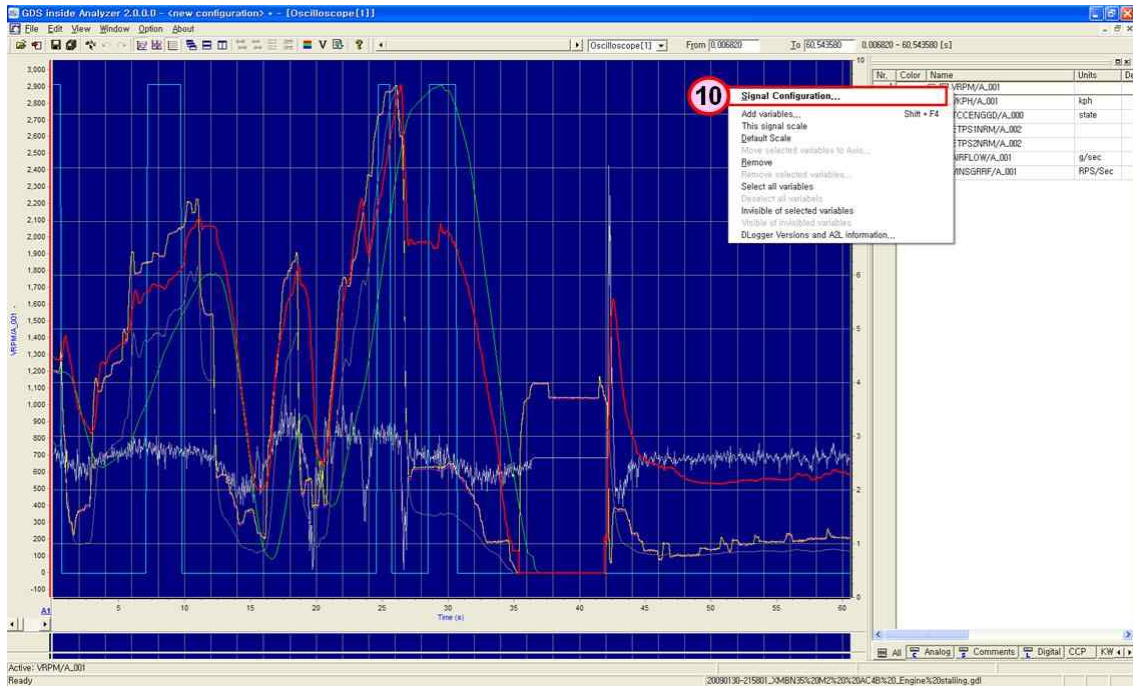
8) Select <one axis per signal> and click OK.



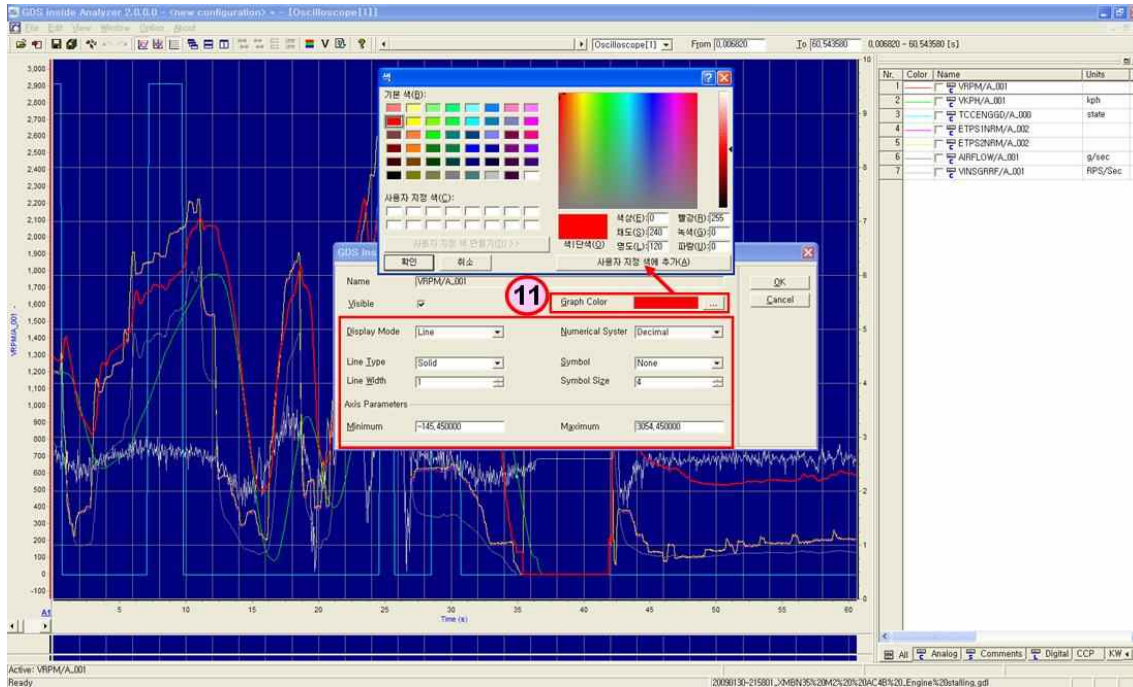
9) A new oscilloscope window is opened.



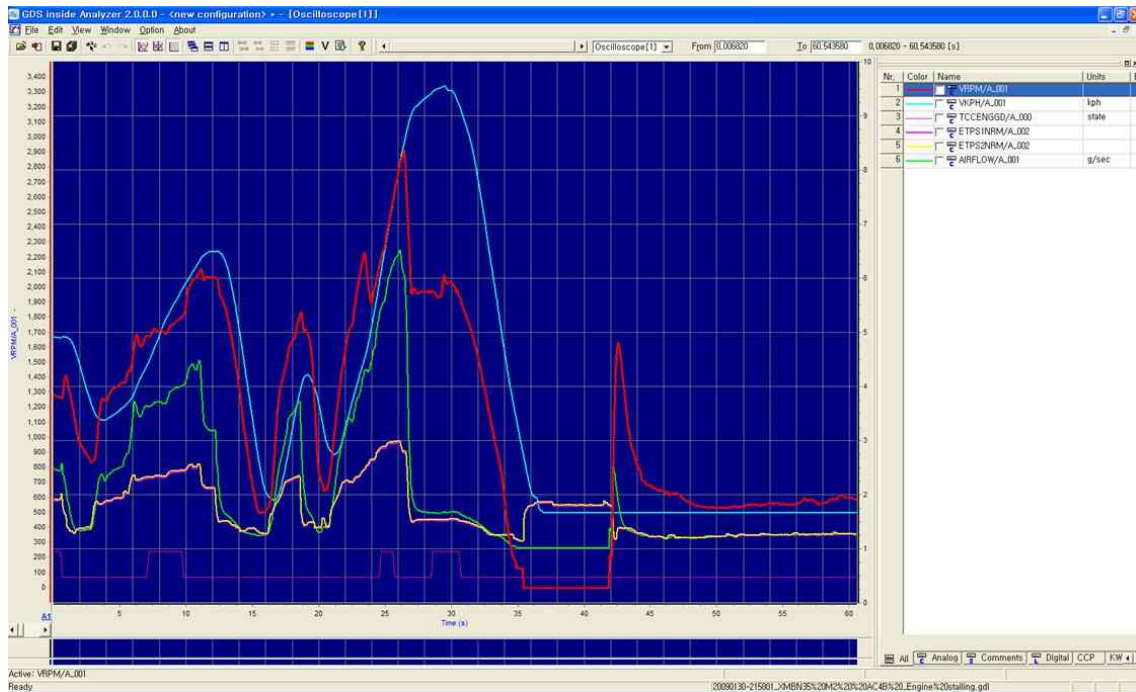
10) Select a variable and select Signal Configuration.



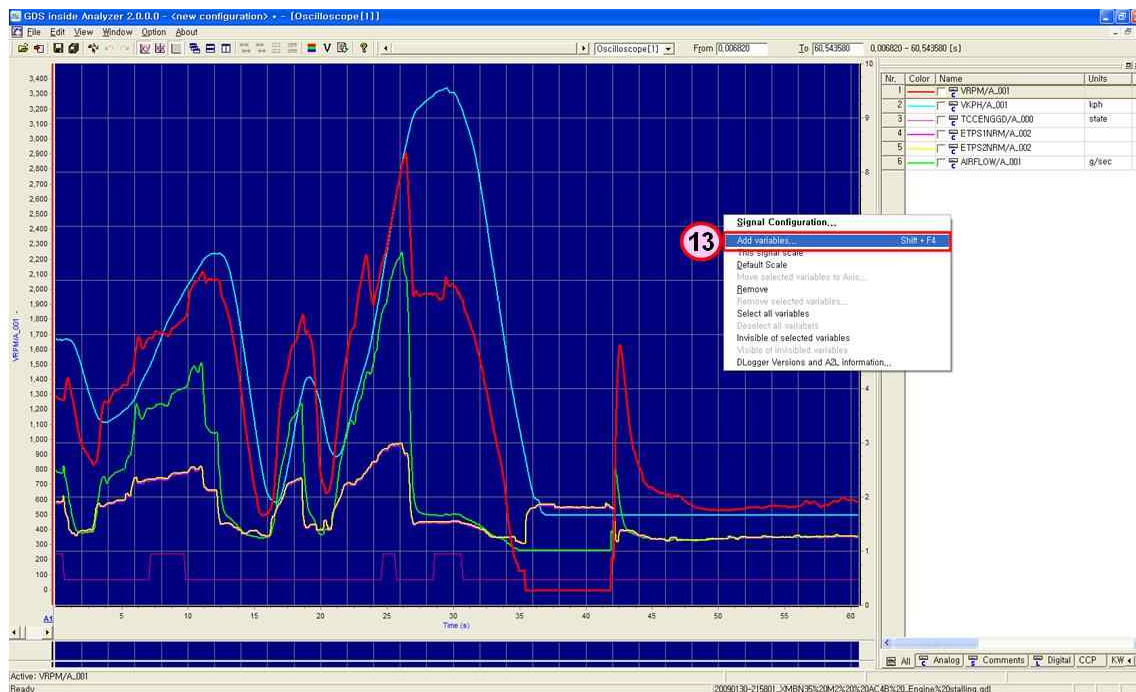
11) Set color and line width, etc. and click OK.



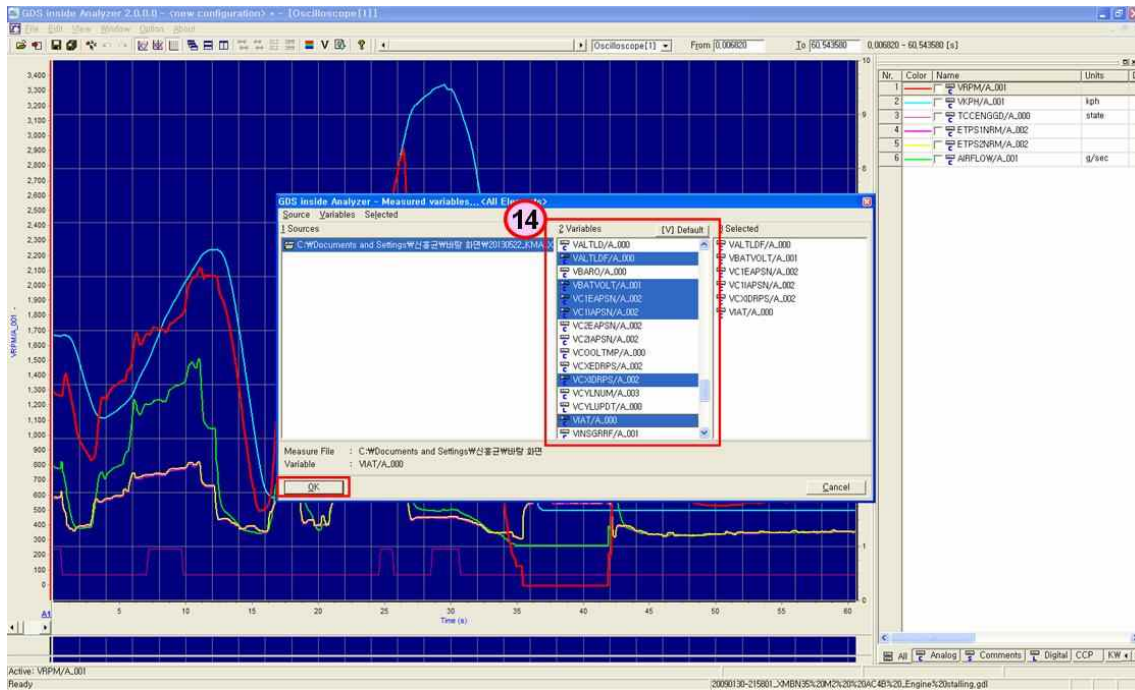
12) Data is analyzed.



13) Select Add variables.



14) Add the variables needed for analysis.




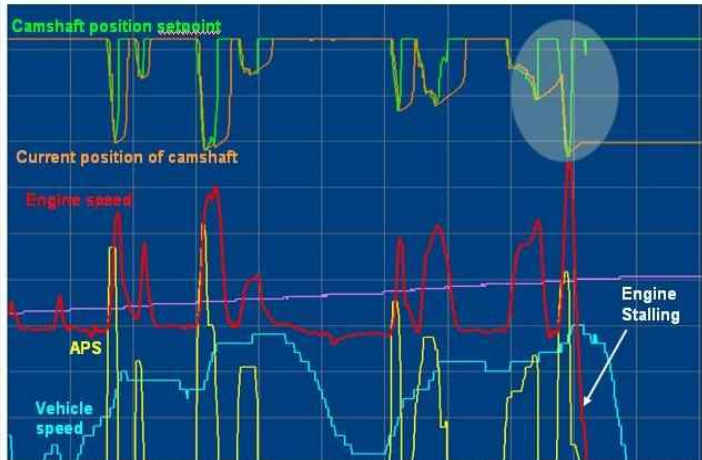
15) Data is analyzed.

### 6.3 Cases of analysis

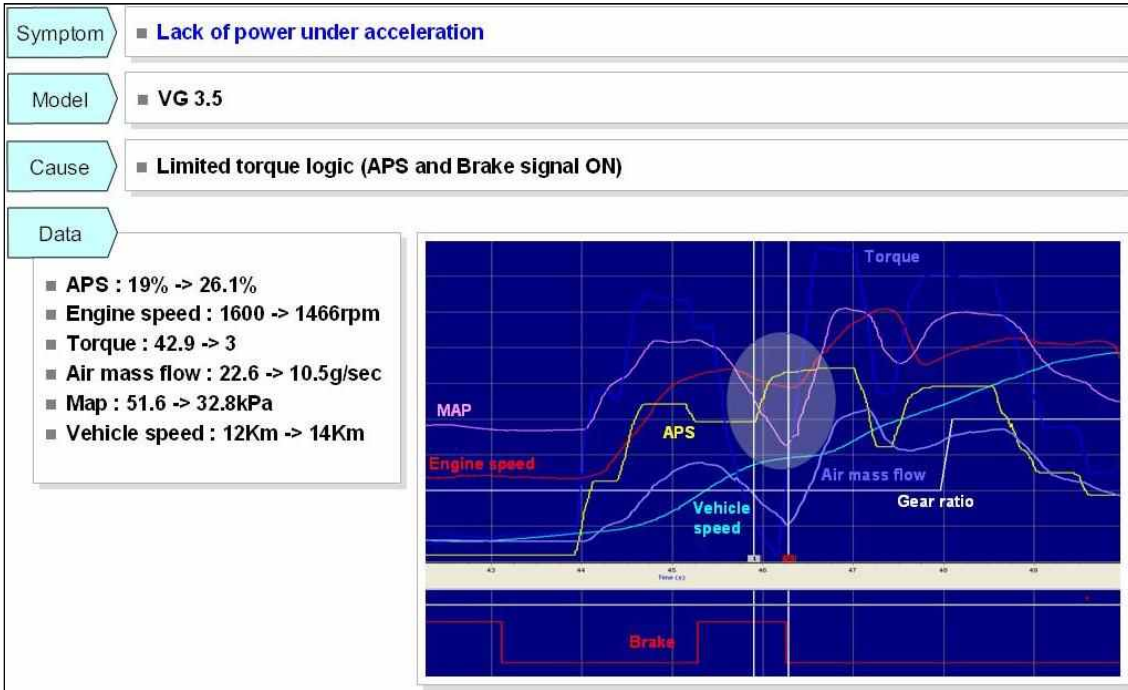
This part introduces 5 examples of recorded data analysis.

1) Engine stalling upon braking after cold start of MG 2.0

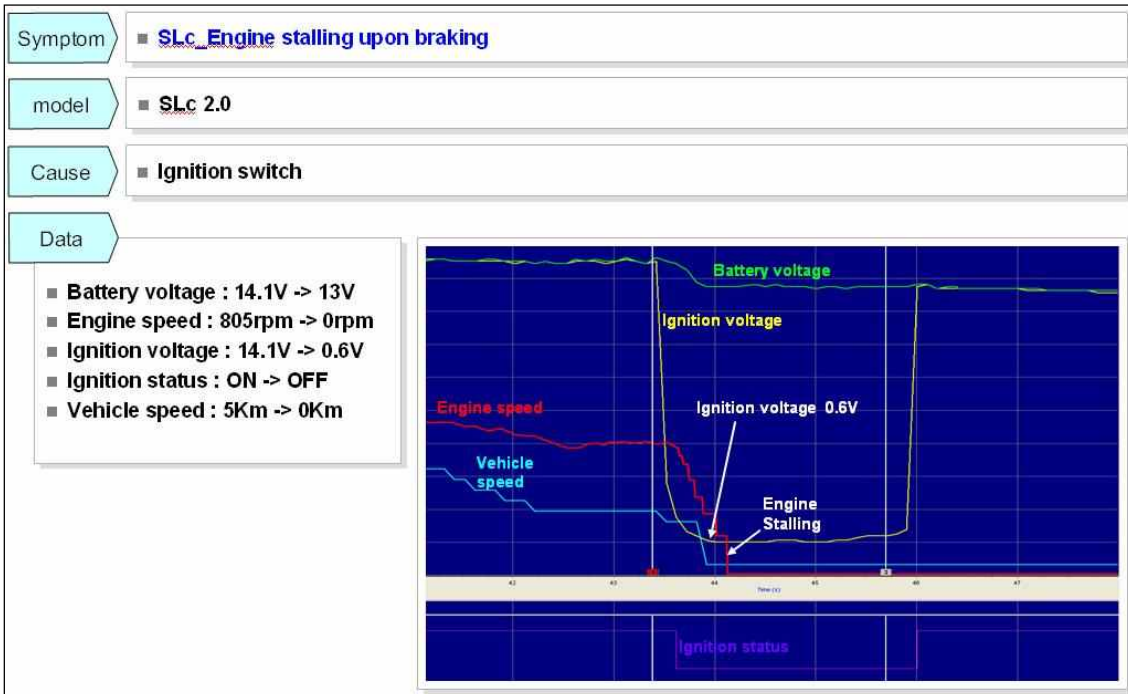
Symptom	■ <b>Engine stalling upon braking after cold start</b>
Model	■ <b>MG 2.0</b>
Cause	■ <b>OCV</b>
Data	<ul style="list-style-type: none"> <li>■ <b>APS : 12.5% -&gt; 0%</b></li> <li>■ <b>Engine speed : 1770rpm -&gt; 0rpm</b></li> <li>■ <b>Camshaft position setpoint : 93.3° -&gt; 129°</b></li> <li>■ <b>Current position of camshaft : 96.7° -&gt; 97.5°</b></li> <li>■ <b>WTS : 55° -&gt; 65°</b></li> <li>■ <b>Vehicle speed : 15Km</b></li> </ul>

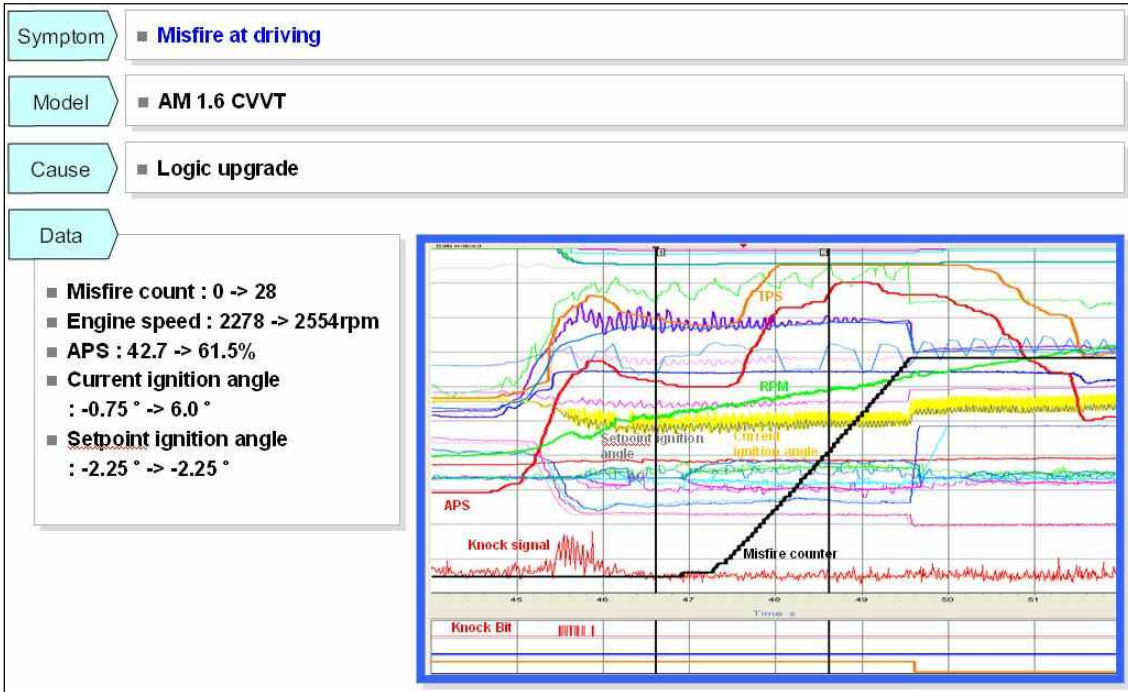
2) Lack of power under acceleration of VG 3.5



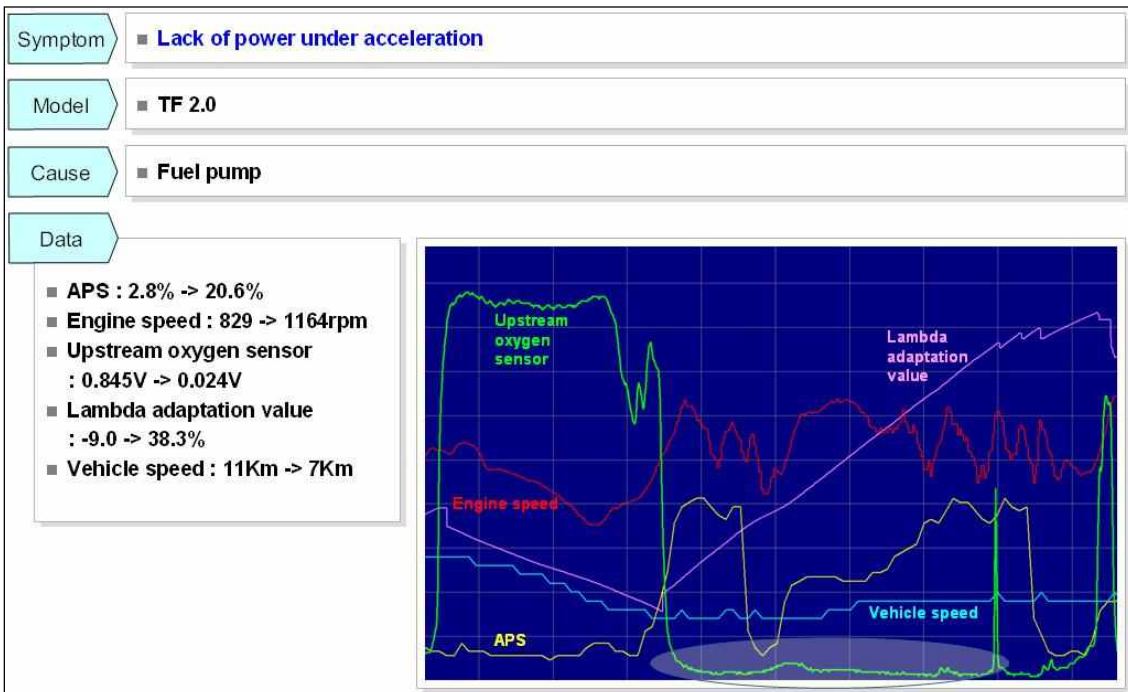
3) Engine stalling upon braking of SLc 2.0



4) Misfire at driving of AM 1.6



5) Lack of power under acceleration of TF 2.0



---

## 7. User site

---

User site is the website for all the users of DLogger Program and is used to request the authority related the use of DLogger, share the data such as programs and manuals, notify the content of program update, request analysis of recorded data, request improvement of programs and errors, and share examples.

The address is <https://dlogger.kia.com>.

### 7.1 How to request authority

---

To use DLogger Program, you should request the authority and obtain the approval.

#### 7.1.1 Case of a Kia employee

---

An employee should check and write all the items in the registration screen, request the authority, and obtain the approval, too, in order to use DLogger Program. The ID is the Kia employee number.

Fig. 7-1 How to request right – Employee

The screenshot shows the KIA DLogger registration interface. At the top, there is a header with the KIA DLogger logo on the left and a 'Welcome!' message on the right. Below the header, there is a 'Join Information' section with a language selection dropdown set to 'English'. A 'Register' button and a 'Cancel' button are located to the right of the language dropdown. The main registration form is titled 'Member Information' and contains the following fields:

* User ID	<input type="text"/>	Confirm	<input type="text"/>
* Name	<input type="text"/>	* E-mail	<input type="text"/>
Phone	<input type="text"/> - <input type="text"/> - <input type="text"/>	* Company	Kia <input type="text"/>
* GSW Area	GSW Area <input type="text"/>	* Nationality	Area <input type="text"/> Country <input type="text"/>
Distributor	<input type="text"/>	Dealer	<input type="text"/>
Team Code	<input type="text"/>	Team	<input type="text"/>

#### 7.1.2 Case other than an employee

---

The person other than an employee should write all the items and obtain the approval in the non-member registration screen to use the functions. The applicant should write the ID.

Fig. 7-2 How to request authority – Person other than an employee

The screenshot shows the KIA DLogger registration interface, which is identical to the one in Fig. 7-1. It features the KIA DLogger logo, a 'Welcome!' message, a 'Join Information' section with a language dropdown set to 'English', and 'Register' and 'Cancel' buttons. The main registration form is titled 'Member Information' and contains the following fields:

* User ID	<input type="text"/>	Confirm	<input type="text"/>
* Name	<input type="text"/>	* E-mail	<input type="text"/>
Phone	<input type="text"/> - <input type="text"/> - <input type="text"/>	* Company	Kia <input type="text"/>
* GSW Area	GSW Area <input type="text"/>	* Nationality	Area <input type="text"/> Country <input type="text"/>
Distributor	<input type="text"/>	Dealer	<input type="text"/>
Team Code	<input type="text"/>	Team	<input type="text"/>

---

### 7.1.3 Password policy

---

#### 1) Login

In case of login for the first time, a page appears to change initial password.

The password should consist of the combination of 8 or more English letter(s), figure(s), and specific letter(s) or 10 or more English letter(s) and figure(s).

Failure in login is accumulated and the account is blocked in case of 5 times of login failure.

If 6 months (180 days) or longer period has elapsed since change of the password, the password should be changed.

If 90 or more days have elapsed since lost login, the account enters into dormancy state.

#### 2) Re-issuance of password

If the member ID, name, and e-mail of previously registered member are consistent, request for re-issuance is completed.

When the manager registers the authority, the authority is notified by e-mail to the user with initial password.

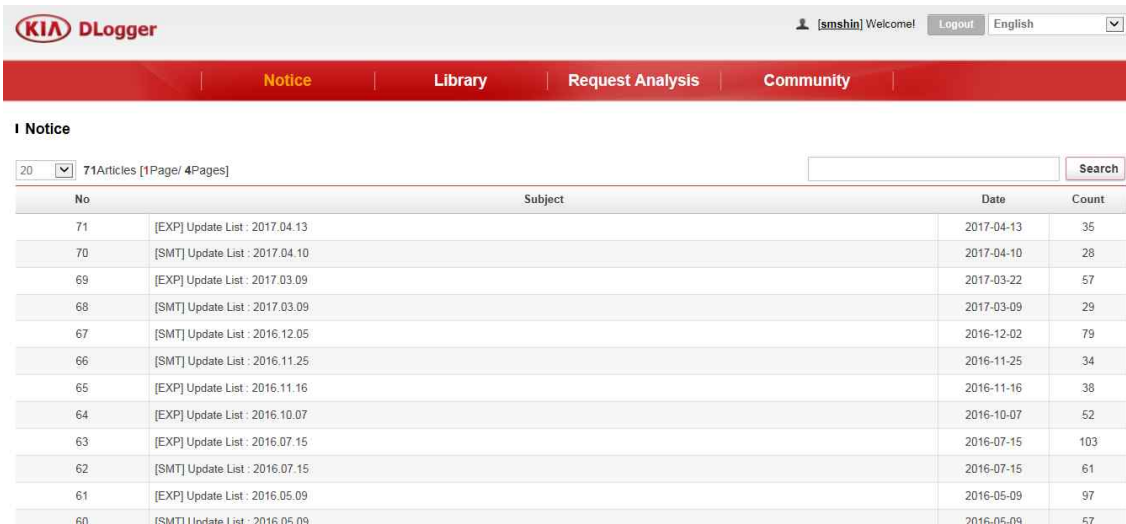
If the user logs in for the first time, a page appears to change initial password.

### 7.2 Notice

---

Details of program update and other matters are noticed.

Fig. 7-3 Matters of Notice



The screenshot shows the KIA DLogger interface. At the top, there is a navigation bar with 'Notice', 'Library', 'Request Analysis', and 'Community'. Below this, the 'Notice' section is active, displaying a table of 71 articles. The table has columns for 'No', 'Subject', 'Date', and 'Count'. A search bar is located at the top right of the table area.

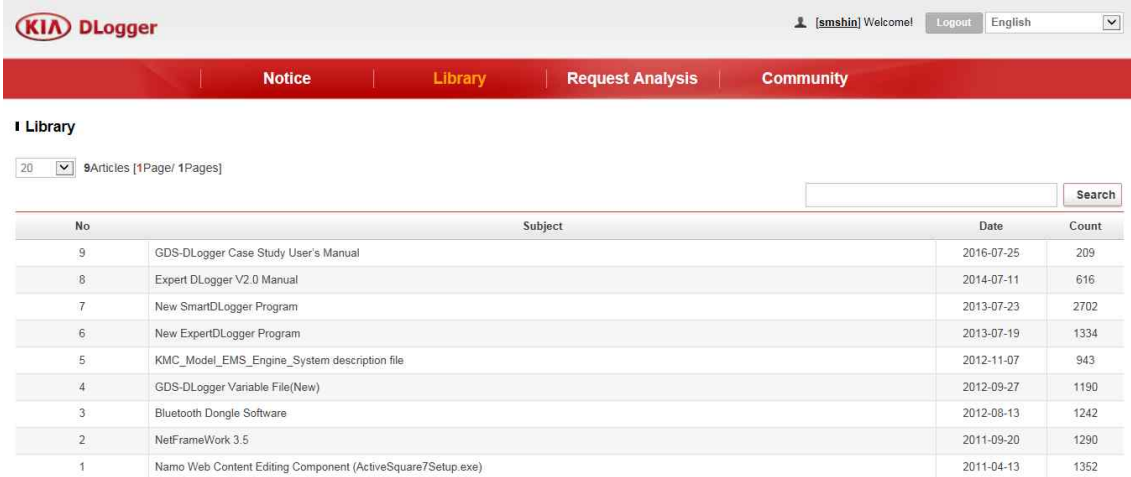
No	Subject	Date	Count
71	[EXP] Update List : 2017.04.13	2017-04-13	35
70	[SMT] Update List : 2017.04.10	2017-04-10	28
69	[EXP] Update List : 2017.03.09	2017-03-22	57
68	[SMT] Update List : 2017.03.09	2017-03-09	29
67	[SMT] Update List : 2016.12.05	2016-12-02	79
66	[SMT] Update List : 2016.11.25	2016-11-25	34
65	[EXP] Update List : 2016.11.16	2016-11-16	38
64	[EXP] Update List : 2016.10.07	2016-10-07	52
63	[EXP] Update List : 2016.07.15	2016-07-15	103
62	[SMT] Update List : 2016.07.15	2016-07-15	61
61	[EXP] Update List : 2016.05.09	2016-05-09	97
60	[SMT] Update List : 2016.05.09	2016-05-09	57



### 7.3 Library

Library has all the data needed for users in relation to DLogger Program and manual.

Fig. 7-4 Library



No	Subject	Date	Count
9	GDS-DLogger Case Study User's Manual	2016-07-25	209
8	Expert DLogger V2.0 Manual	2014-07-11	616
7	New SmartDLogger Program	2013-07-23	2702
6	New ExpertDLogger Program	2013-07-19	1334
5	KMC_Model_EMS_Engine_System description file	2012-11-07	943
4	GDS-DLogger Variable File(New)	2012-09-27	1190
3	Bluetooth Dongle Software	2012-08-13	1242
2	NetFrameWork 3.5	2011-09-20	1290
1	Namo Web Content Editing Component (ActiveSquare7Setup.exe)	2011-04-13	1352

### 7.4 Request for analysis

A DLogger user may use the webpage to be supported with analysis of recorded data.

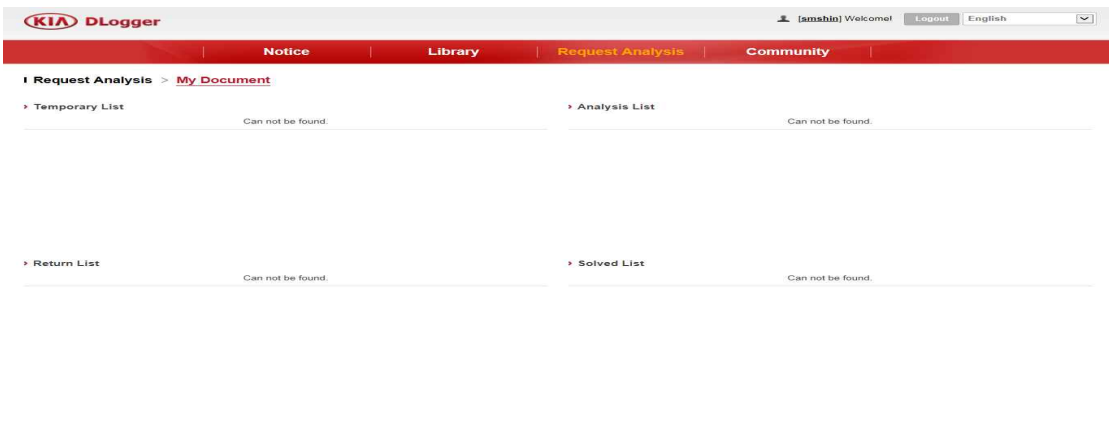
It consists of 3 screens: My Document, Analysis List, and BookMark List.

My Document consists of Temporary List prepared by login user, Analysis List, Return List, and Solved List.

Request List is the list of the requests made by the users in the same area with the login user.

If a login user mark in Request List, confirmation is possible in BookMark List.

Fig. 7-5 Request – My Document



Request Analysis > My Document			
Temporary List	Can not be found.	Analysis List	Can not be found.
Return List	Can not be found.	Solved List	Can not be found.

Fig. 7-6 Request Analysis – Request List

**KIA DLogger** [smshin] Welcome! Logout English

Notice | Library | **Request Analysis** | Community

Request Analysis > Request Analysis

Start Date: [ ] End Date: [ ] System: [ ] Symptom: [ ] Search

Model: [ ] Status: [ ] Subject: [ ]

20 [ ] 0 Articles [1Page/ 0Pages] Write

BookMark	Date	Request Type	Model	System	Area	Symptom	Subject	Approval Process	Name	Status
<input type="checkbox"/>	2017-05-08		DM 2.0		HMC		주행중 출력거림및 진동		윤주철	Completed
<input type="checkbox"/>	2017-05-08		VI 5.0	KEFICO >> ME17 (Tau)	HMC		주행중 간헐적 가속불량		윤주철	Completed
<input type="checkbox"/>	2017-05-08		NF F/L LPI	CONTINENTAL >> SIM2K-142	HMC		NF F/L 간헐적 종속에서 출력 거림 현상		고재영	Completed
<input type="checkbox"/>	2017-05-08		LF 2.0	CONTINENTAL >> SIM2K-241/245	HMC		냉간 시동시 시동꺼짐		윤주철	Completed
<input type="checkbox"/>	2017-05-08		DM 2.0	BOSCH >> EDC17C	HMC		주행중 간헐적 시동 꺼짐 발생		윤주철	Completed
<input type="checkbox"/>	2017-05-08		IG LPI		HMC		LSTR 모드 시동시 시동꺼짐		윤주철	Completed
<input type="checkbox"/>	2017-05-		IG TAU		HMC		주행중 시동 꺼짐		윤주철	Completed

Fig. 7-7 Request Analysis – BookMark List

**KIA DLogger** [smshin] Welcome! Logout English

Notice | Library | **Request Analysis** | Community

Request Analysis > BookMark List

Start Date: [ ] End Date: [ ] Request Type: [ ] Select Language: [ ] Model: [ ] Search

System: [ ] Area: [ ] Symptom: [ ] Init

Status: [ ] Subject: [ ]

20 [ ] 0 Articles [1Page/ 0Pages] Write

Can not be found.

## 7.5 Community

Community consists of Case Study and Q&A. Case Study is the web page that DLogger users may suggest the matters for improvement of the program and request correction of errors. Q&A is the web page that question and answer about DLogger.

Fig. 7-8 Community – Case Study

**KIA DLogger** | [smshin] Welcome! | Logout | English

Notice | Library | Request Analysis | **Community**

**Community > Case Study**

Select Language | Area | Country | FuelType | EMS | Model | Symptom | Cause | Search

20 | 264 Articles [1Page/ 14Pages]

No	Area	Country	FuelType	EMS	Model	Symptom	Cause	CaseNo	Date
264	Asia & Pacific	Singapore	Gasolin	Bosch/Kefico (epsilon/Kapa/Alpha/Gamma/Nu/Lamda/Tau Engine)	YD 1.6 GD	Others (Knocking/Misfring/Cr use Control/ISG/DTC etc.)	PCSV open stuck		2017-03-21
263	Africa & Middle East	Qatar	Gasolin	Bosch/Kefico (epsilon/Kapa/Alpha/Gamma/Nu/Lamda/Tau Engine)	YD 1.6 GD	Poor acceleration/Lack of Power	Tone wheel of flywheel	004	2017-03-21
262	아미	Singapore	가솔린	보쉬/케피코 (엡실론/카파/알파/감마/누/람다/타우 엔진)	YD 1.6 GD	기타 (크루징 컨트롤 등/ISG/DTC 등)	PCSV 열림 고착으로 연료 오버 플로우		2017-03-21
261	아중동	Qatar	가솔린	보쉬/케피코 (엡실론/카파/알파/감마/누/람다/타우 엔진)	YD 1.6 GD	가속불량/출력 부족	분할 불량	004	2017-03-21
260	Asia & Pacific	Korea	Diesel	Bosch (UD/A/S/U2/R/S2 Engine)	QL 2.0	Others (Knocking/Misfring/Cr use Control/ISG/DTC etc.)	ISG prohibition by DPF regeneration		2017-03-06
259	Asia & Pacific	NewZealand	Diesel	Bosch (UD/A/S/U2/R/S2 Engine)	UM 2.2	Others (Knocking/Misfring/Cr use Control/ISG/DTC etc.)	ISG prohibition by battery (SOC)	004	2017-03-06
258	Asia & Pacific	NewZealand	Diesel	Bosch (UD/A/S/U2/R/S2 Engine)	UM 2.2	Others (Knocking/Misfring/Cr use Control/ISG/DTC etc.)	ISG prohibition by DPF regeneration		2017-03-06
257	Asia & Pacific	Korea	Diesel	Bosch (UD/A/S/U2/R/S2 Engine)	UM 2.0	Others (Knocking/Misfring/Cr use Control/ISG/DTC etc.)	ISG prohibition by DPF regeneration	003	2017-03-06

Fig. 7-9 Community – Q&A

**KIA DLogger** | [smshin] Welcome! | Logout | English

Notice | Library | Request Analysis | **Community**

**Community > Q&A**

20 | 0 Articles [1Page/ 0Pages]

Search Write

Can not be found.

## 8. How to utilize DLogger devices

DLogger users are classified into Smart DLogger users and Expert DLogger users. In general, Smart DLogger is used by the employees of service centers, overseas distributors and dealers.

Smart DLogger users generate events and record and analyze data using Smart DLogger usually but, if it is needed to record additional variables or if it is required for the R&D center to record specific variables, the user may record the data with the support of event files from quality team or head office and may be supported with analysis.

This page introduces all the cases of utilization of DLogger device to record data using Smart DLogger or the support of event files.

Fig. 8-1 Automatic process of Smart DLogger

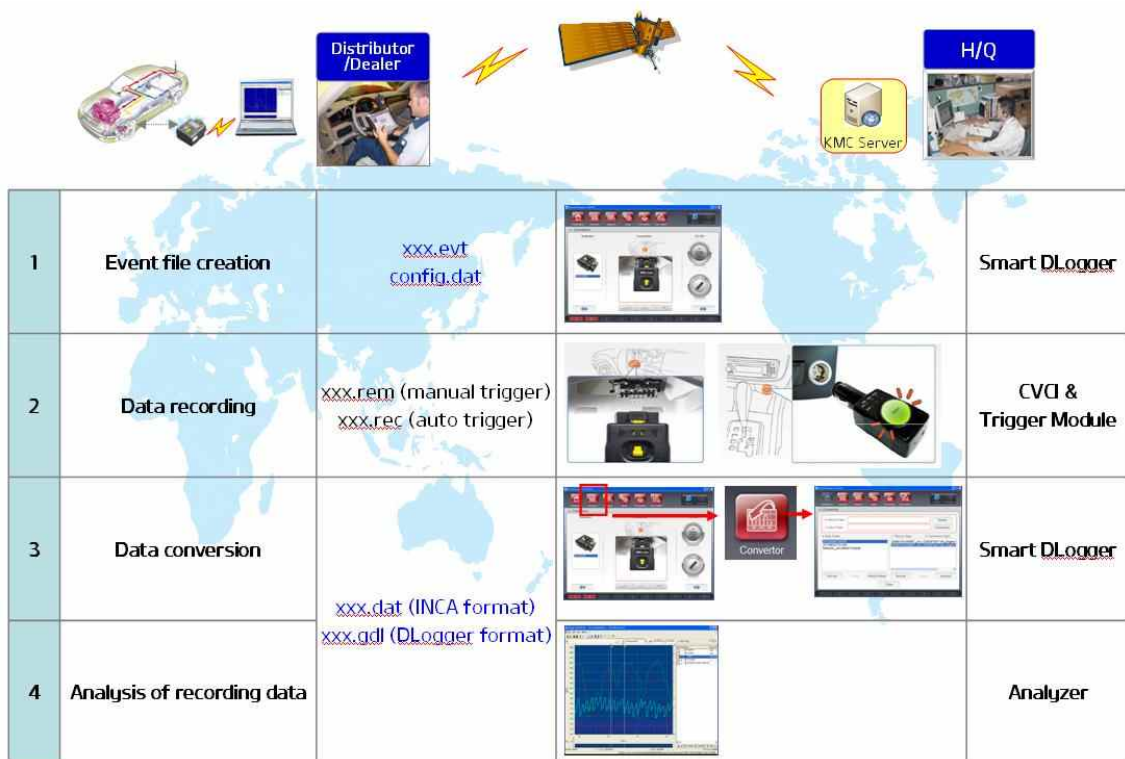
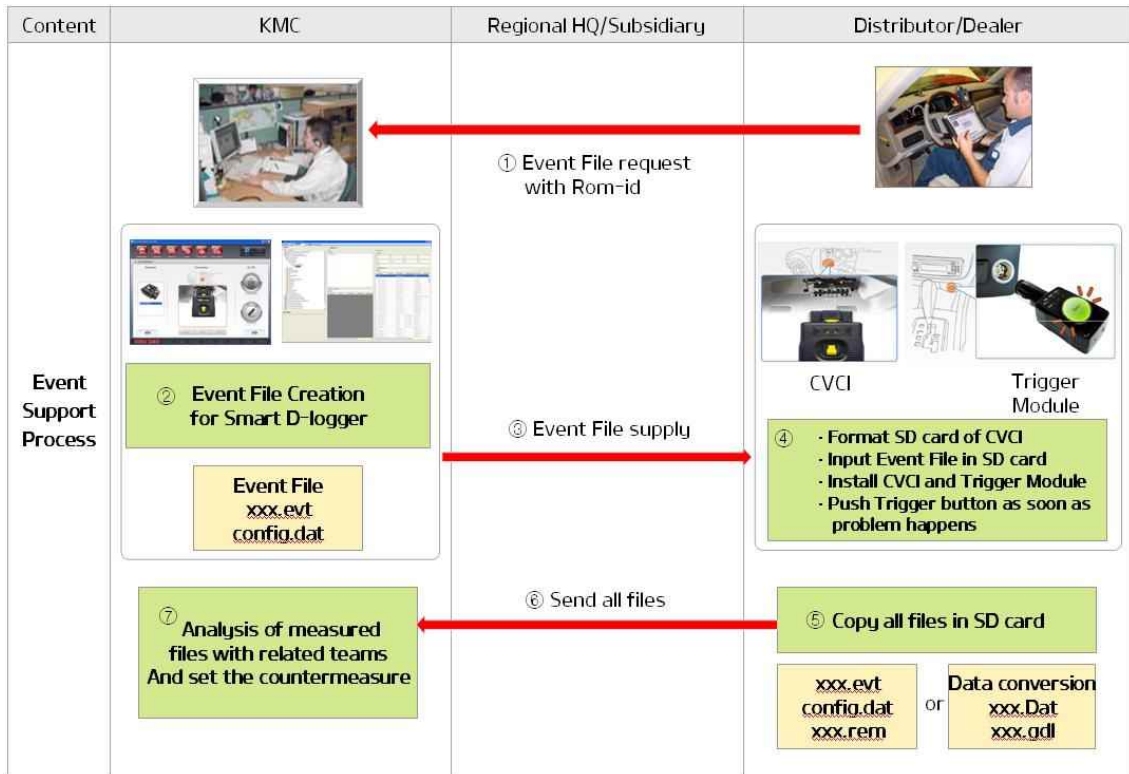


Fig. 8-2 Event support process



## 8.1 Utilizing 1 set of DLogger devices

### 8.1.1 Connecting and using indoor OBD terminal

- \* Gasoline engine

Kefico – Alpha 2, Gamma, Epsilon, Kappa, Lambda, and Nu engines

Continental – Theta 1, Theta 2, and Nu engines, etc

- \* Diesel engine

Bosch – U, U2, D, A, A2, S, S2, and R engines

Delphi – J2.9, U2 1.4, and A2 engines

- \* Automatic transmission

New small, current generation, new generation 4/5 speed,

Front/Rear 6/8 speed

- \* CAN monitoring

HEV (C-CAN)

---

## 8.1.2 Connecting and using engine room 20-pin terminal

---

- \* Gasoline engine

  - Delphi – Lambda 1, Lambda 2, and Mu engines

  - Kefico – Tau engine

  - Continental – HEV (Theta and Nu engines)

- \* CAN monitoring

  - HEV (H-CAN) – 1 channel

  - HEV : Engine room 20-pin terminal (H-CAN) + Indoor OBD terminal

    - (C-CAN) – 2 channels

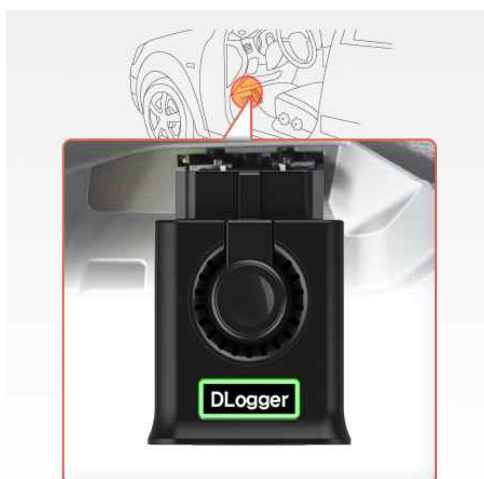
Fig. 8-3 Connecting and using indoor OBD terminal



1) CVCI



2) VCI-II



3) CVCI-II

---

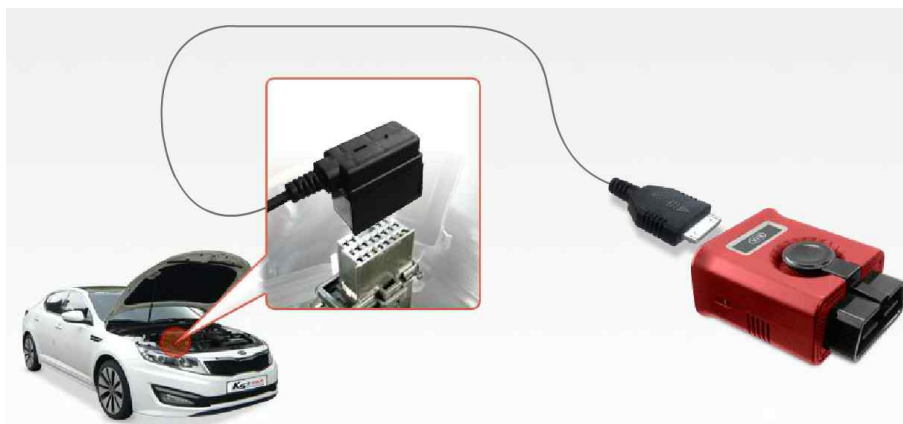
**Fig. 8-4 CVCI : Connecting and using engine room 20-pin terminal**

– Use of additional 8-to-20-pin cable in the state of connection of CVCI OBD terminal



**Fig. 8-5 VCI-II : Connecting and using engine room 20-pin terminal**

– Use of additional 30pin-to-20-pin cable in the state of connection of VCI-II OBD terminal



---

Fig. 8-6 CVCI-II : Connecting and using engine room 20-pin terminal

- Use of additional 30pin-to-20-pin cable in the state of connection of CVCI-II OBD terminal



### 8.1.3 Connecting and using body CAN terminal

---

\* Body CAN monitoring

Fig. 8-7 Connection and use of body CAN







3) CVCI-II

## 8.2 Utilizing 2 set of Compact VCI

---

If you intend to use 2 sets of Compact VCI, generate the event files manually or insert SD card with support.

There may be many cases to use 2 sets of Compact VCI using various sets of combination such as CCP (Can Calibration Protocol), XCP (Extended Calibration Protocol), KWP DDLI (Dynamically Define Local Identifier), and CAN Monitoring of the system and Channels 1/2. Two cases are introduced below.

### 1) HEV CAN Monitoring

CVCI 1 : Engine room 20-pin terminal H-CAN monitoring

CVCI 2 : Indoor OBD terminal C-CAN monitoring

### 2) Engine + Body CAN Monitoring

CVCI 1 : Engine room 20-pin terminal Mu/Lambda/Tau engine CCP recording

CVCI 2 : Indoor OBD terminal body CAN monitoring

---

## 9. Contacts

---

### \* NORTH AMERICA

- GIT America
- C : Sean Jo
- T : 1-714-433-2180
- E : [seanjjo@gitauto.com](mailto:seanjjo@gitauto.com)

### \* EUROPE

- GIT Europe
- C : Na num Park
- T : 070-7618-7750
- E : [nanumpark@gitauto.com](mailto:nanumpark@gitauto.com)

### \* CHINA

- GIT China
- C : Seung Jun Kim
- T : 070-7500-1061
- E : [seungjun@gitauto.com](mailto:seungjun@gitauto.com)

### \* GENERAL

- GIT Korea
- C : Young Il Kim
- T : 82-2-2189-3378
- E : [ics@gitauto.com](mailto:ics@gitauto.com)

### \* KOREA

- GIT Korea
- C : Yong Tae Jo
- T : 02-2189-3446
- E : [moljoyou2@gitauto.com](mailto:moljoyou2@gitauto.com)